

# RESTORATION PARTS GUIDE

ROVERS NORTH.COM

The Source for Classic Land Rover Parts

Volume 1

**DEFENDER**  
KEEP IT REAL



Family Owned by Enthusiasts since 1979

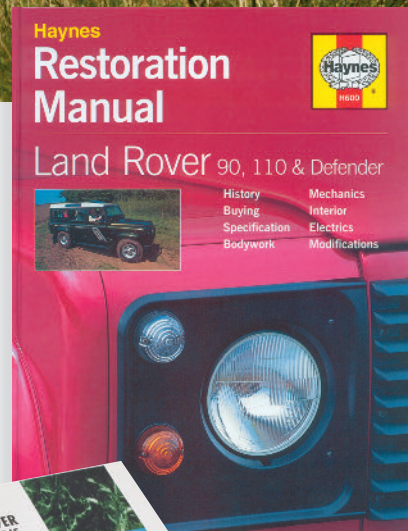

## DEFENDER 90 NAS Owner's Manual

As equipped in 1994, 95, 1997 Defender 90.  
Reproduced from factory original.

1994, 95 Defender 90 NAS Owner's Manual.....RNS571 \$ 129.50

1997 Defender 90 NAS Owner's Manual.....RNS572 \$ 129.50

Haynes  
Restoration  
Manual  
DEFENDER  
BOOK57  
\$ 34.60



## Diesel Timing Tool Kit

Diesel 2.5 NA, 2.5 Turbo, 200 Tdi & 300 Tdi engines. For engine & injection pump timing adjustments.

RNT2029 \$ 119.00



## Hub Nut Tool

2 1/8" for servicing the adjuster and lock nuts on hub bearings.

RNF406 \$ 14.39

Tool Bar RNT0004 \$ 6.18

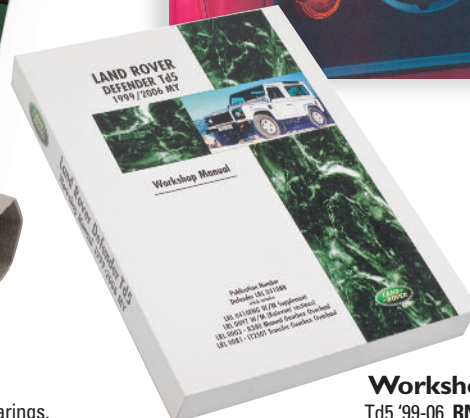

## Workshop Manuals

Td5 '99-06 RNI188 \$ 120.75

300Tdi '96-98 RNN220 \$ 99.95

Petrol/Diesel '93-95 RNS723 \$ 119.95



# Restoration Parts for Land Rover DEFENDER



For owners who intend to keep their Land Rover forever, we are excited to offer you our new selection of original manufactured galvanized chassis. The foundation of any great Land Rover. No component better exemplifies

Land Rover strength, no component more effects its value. So we have started with the best.

Our entire range of Defender chassis are assembled on factory jigs to ensure exacting dimensional accuracy. Bare units are then enhanced with features unique to NAS Defender. This allows us to offer you a direct replacement for early NAS vehicles with all the improvements found on latest Puma models. Then each chassis is hot dipped galvanized to ensure a lifetime of corrosion resistance.

Experience has taught us that one chassis does not fit all. Some owners want to restore their Land Rover to original factory condition and some building their ultimate Land Rover, want to fit other engines or bodies offered by Land Rover. So we have taken our most requested chassis models to create this selection for you.

In addition to our NAS chassis selection we also offer original manufactured replacement bulkheads for NAS 90s and galvanized replacement foot well panels for both NAS 90 and 110 to help solve your corrosion issues.

Please feel free to contact us with questions and for product advice. The entire range of Land Rover Genuine Parts is available through Rovers North. We have lots of knowledge and experience to share and look forward to helping you with your next project.

*Andrea and Mark Koberney*



*North America's number one choice for chassis selection at Rovers North.*

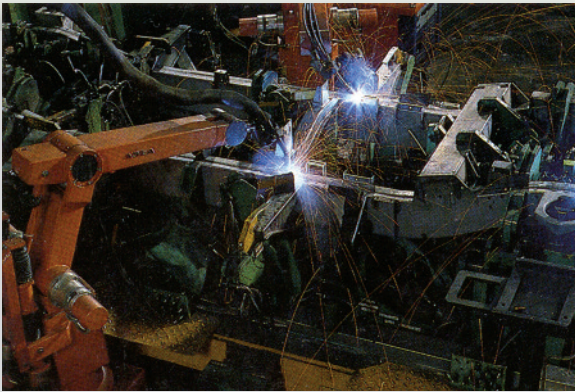

*Built on Land Rover chassis jigs for superior dimensional accuracy. Photo: Land Rover.*

## Land Rover Defender Restorations

**Introducing our new range of galvanized chassis for Land Rover Defender.** Built on factory jigs for dimensional accuracy and hot dipped galvanized for a long corrosion resistant life. Start with a superior chassis and Genuine replacement parts to restore your Land Rover Defender, only from Rovers North.

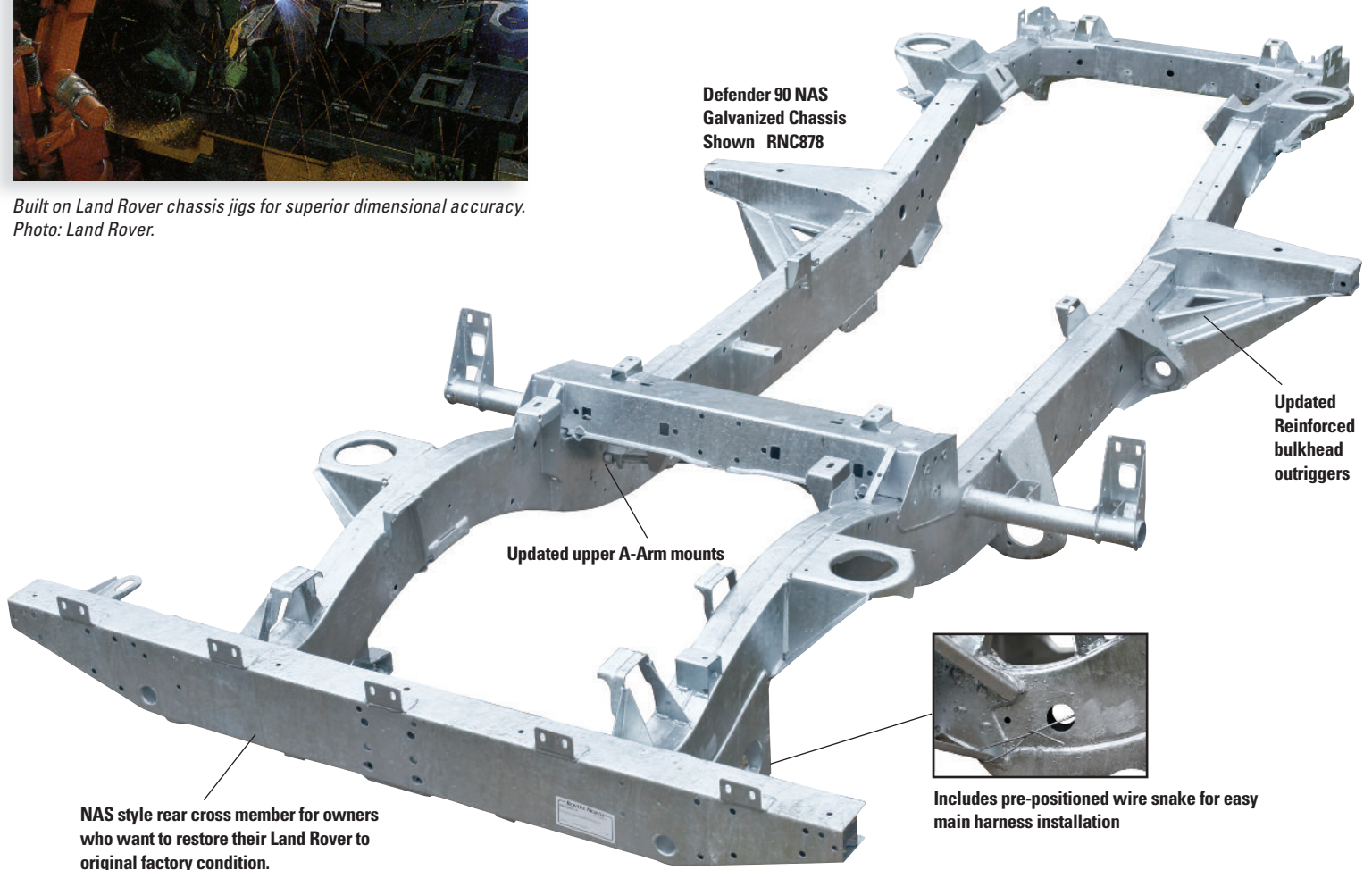

# Chassis - DEFENDER

All our chassis are shipped via truck freight and are built to travel. You will be contacted with actual freight charges prior to shipping.



Introducing our new selection of Defender galvanized chassis, packed with all the improved features found on the latest Defender. Built on factory jigs for accuracy and hot dipped galvanized for long corrosion resistant life. Now is the time to build your ultimate Defender.

Defender 110 V8 Galvanized Chassis shown RNH710

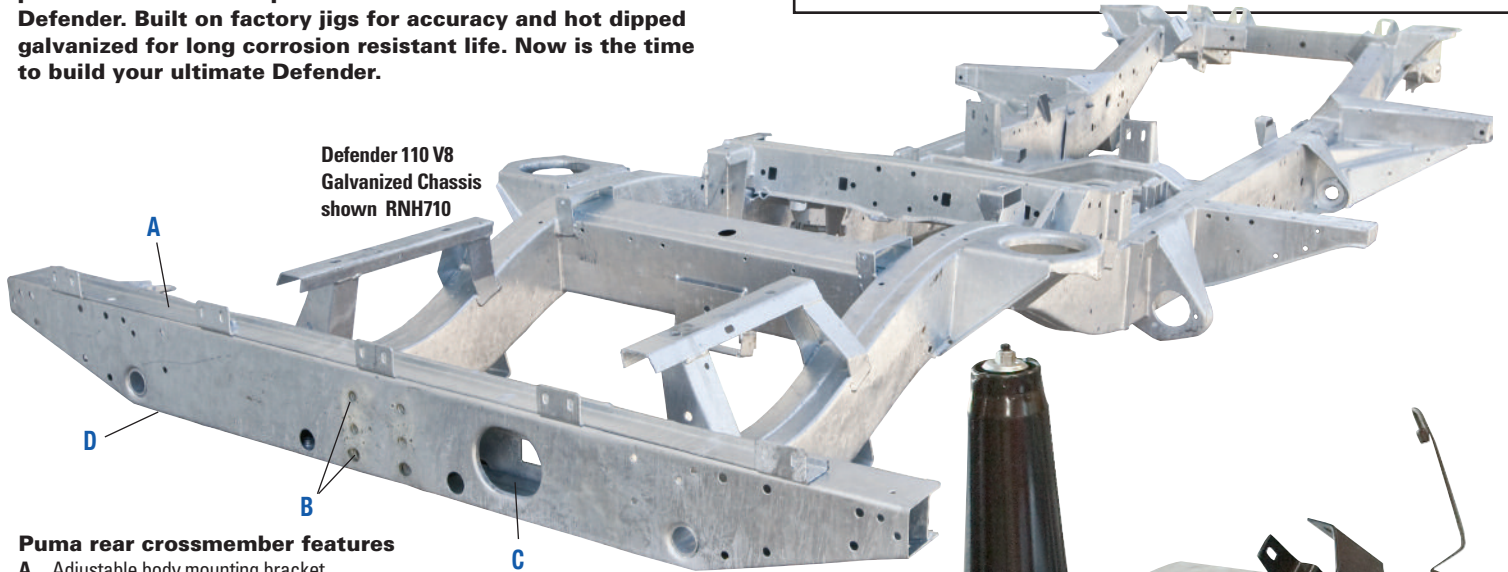

### Puma rear crossmember features

- A. Adjustable body mounting bracket.
- B. Integral fixing nuts for tow plate - for easy mounting.
- C. Recessed mounting for towing plug - for better protection.
- D. Bottom mounting blocks for rear NAS step.

### NAS rear crossmember

Optional on 90 chassis, as fitted to NAS Defenders.

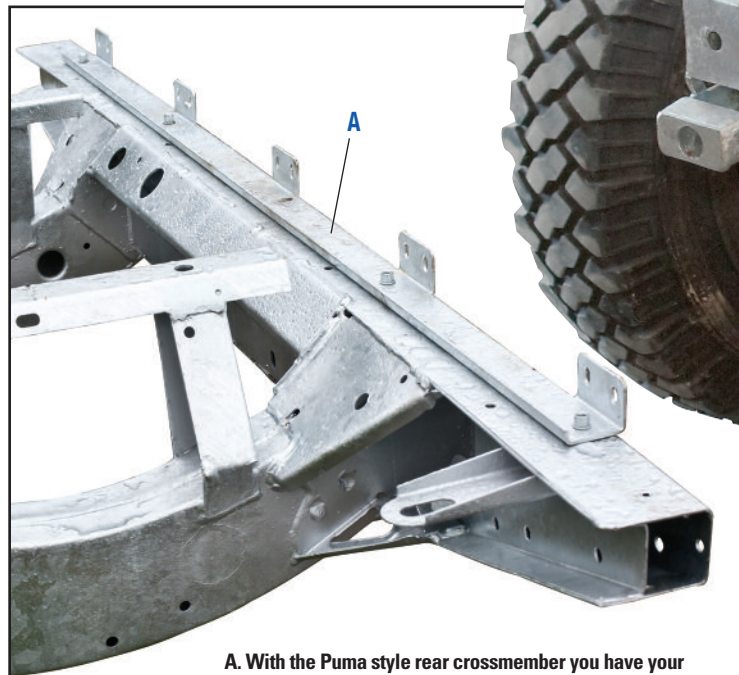

A. With the Puma style rear crossmember you have your choice of 2 types of adjustable rear body mounting brackets. Exterior mount tabs (shown) RNS237G Interior (hidden) mount tabs with captured nuts RNS238G



### All Rovers North Galvanized Defender Chassis are supplied with...

- Your choice of adjustable rear body mounting bracket on chassis ordered with Puma rear crossmember
- Galvanized gearbox crossmember to match your engine type (V8, 200Tdi/NA, 300Tdi)
- Updated rear top link bushings
- Pre-positioned wire snake for easy main harness installation



**Defender 90 NAS  
Galvanized Chassis  
Shown RNC878**

**Defender Galvanized Chassis**

**Defender 90:** Fits all body styles

NAS 90 V8 with NAS rear crossmember.....	<b>RNC878</b>	<b>\$ 3250.00</b>
NAS 90 V8 with Puma rear crossmember.....	<b>RNS365</b>	<b>\$ 3159.00</b>
90 300Tdi with NAS rear crossmember.....	<b>RNS559</b>	<b>\$ 3290.00</b>
90 300Tdi with Puma rear crossmember.....	<b>RNS560</b>	<b>\$ 2995.00</b>
90 200Tdi, 2.5 Turbo, 2.5 NA, and 2.5, 2.3 Petrol with Puma rear crossmember.....	<b>RNS561</b>	<b>\$ 2995.00</b>

**Defender 110:** Fits all body styles

NAS 110 V8 with Puma rear crossmember for steel fuel tank.....	<b>RNH710</b>	<b>\$ 3190.00</b>
NAS 110 V8 with Puma rear crossmember for plastic fuel tank*.....	<b>RNS562</b>	<b>\$ 3290.00</b>
110 300Tdi with Puma rear crossmember for steel tank.....	<b>RNH697</b>	<b>\$ 3429.00</b>
110 300Tdi with Puma rear crossmember for plastic fuel tank*.....	<b>RNS564</b>	<b>\$ 3429.00</b>
110 200Tdi, 2.5 Turbo, 2.5 NA, and 2.5, 2.3 Petrol with Puma rear crossmember for steel tank.....	<b>RNS563</b>	<b>\$ 3329.00</b>

**Defender 130:** Fits all body styles (not shown)

130 V8 with Puma rear crossmember for plastic fuel tank.....	<b>RNS565</b>	<b>\$ 3499.00</b>
130 300Tdi with Puma rear crossmember for plastic fuel tank.....	<b>RNS566</b>	<b>\$ 3499.00</b>
130 200Tdi, 2.5 Turbo, 2.5 NA, and 2.5, 2.3 Petrol with Puma rear crossmember for steel fuel tank.....	<b>RNI867</b>	<b>\$ 3499.00</b>

**\*Updated Genuine plastic fuel tank kit** (Includes; fuel tank, pump, sender unit, mounting bracket, rear sway bar and harness link).....**RNK4297** **\$ 951.39**

**We welcome special chassis orders, please give us a call.**

*Defender 90 with Rovers North Galvanized Chassis custom built by Congleton Racing and Restoration.* 

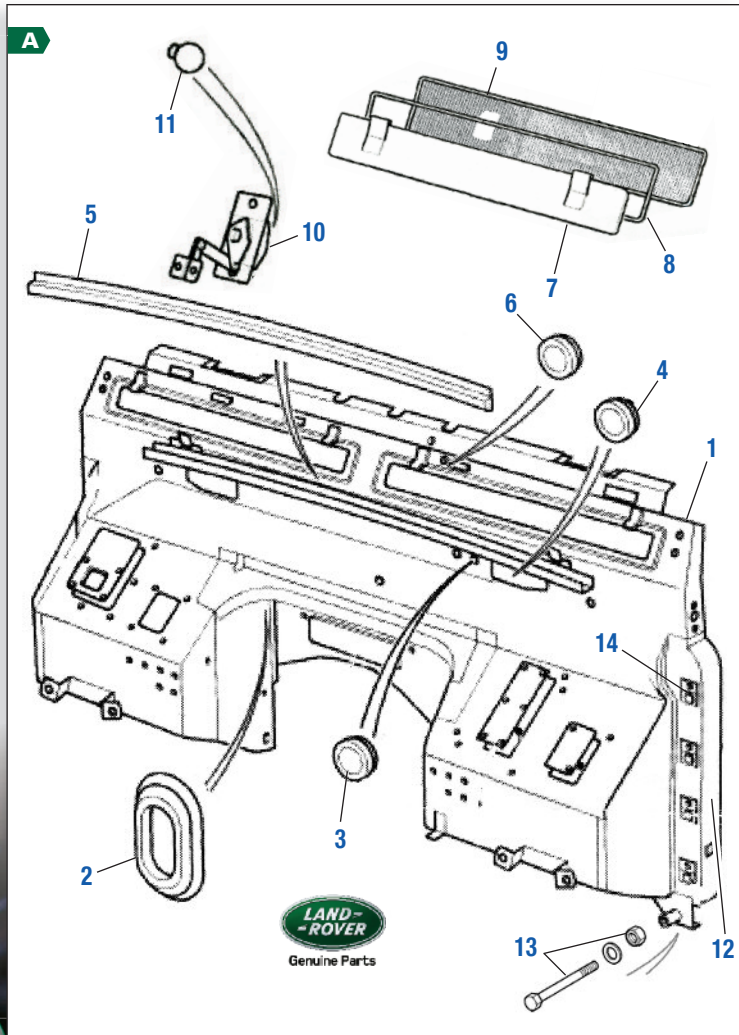

**A Bulkhead Assembly, LHD Defender V8 NAS 90**

Made from the latest Land Rover Galvaneal metal and electrostatic primed for superior corrosion resistance. This is an exact replacement for NAS 90 models. Requires upgrading to the latest wiper wheel boxes offering improved wiper arm performance. Supplied ready for paint. For upgraded wiper wheel boxes use RNS555. Assembled in the USA.

1. **1995 NAS 90** (will easily adapt to 1994), includes #7 .....RNB1995 \$ 2599.00  
 1997 NAS 90, includes #7 .....RNB1997 \$ 2785.00  
 Updated Wiper Wheel Boxes Kit.....RNB1995 \$ 159.95
2. **Plug**.....RNN681 \$ 7.61
3. **Bonnet Buffer, Genuine** .....RNB821 \$ 16.95  
 Bonnet Buffer, ProLine.....PLB821 \$ 2.95
4. **Plug**.....RNN686 \$ 2.98
5. **Drain Channel Seal** .....RNN687 \$ 46.11
6. **Wiper Spindle Blanking Plug to #1A622423** .....RNN688 \$ 3.22  
 Blanking Plug 12x18mm from #2A622424 .....RNN689 \$ 0.98

**Dash Vents**

7. **Dash Vent Lid Assembly RH**.....RNN703 \$ 79.95  
 Dash Vent Lid Assembly LH.....RNN704 \$ 79.95  
 Pin.....RNB846 \$ 5.95
8. **Rubber Seal, Genuine** .....RNE365 \$ 23.50  
 Rubber Seal, ProLine .....PLE365 \$ 20.95
9. **Flyscreen**.....RNI049 \$ 119.95  
 Pop Rivet.....RNN705 \$ 0.65
10. **Vent Control Lever up to 1A622423** .....RNI037 \$ 67.95  
 Vent Control Lever from 2A622424, RH .....RNI669 \$ 169.95  
 Vent Control Lever from 2A622424, LH .....RNI670 \$ 169.95
11. **Air Vent Knob from 2A622424**.....RNI673 \$ 5.66
12. **Replacement Door Post, LH**.....CHAS17 \$ 119.95  
 Replacement Door Post, RH.....CHAS18 \$ 119.95
13. **Bulkhead to Chassis Hardware Kit** (2 bolts, 2 nuts and washers) RNB4261 \$ 44.40
14. **Spire Nut - Wing / Bulkhead**.....RNC815 \$ 1.65  
 Bolt for Spire Nut.....RNC844 \$ 1.96

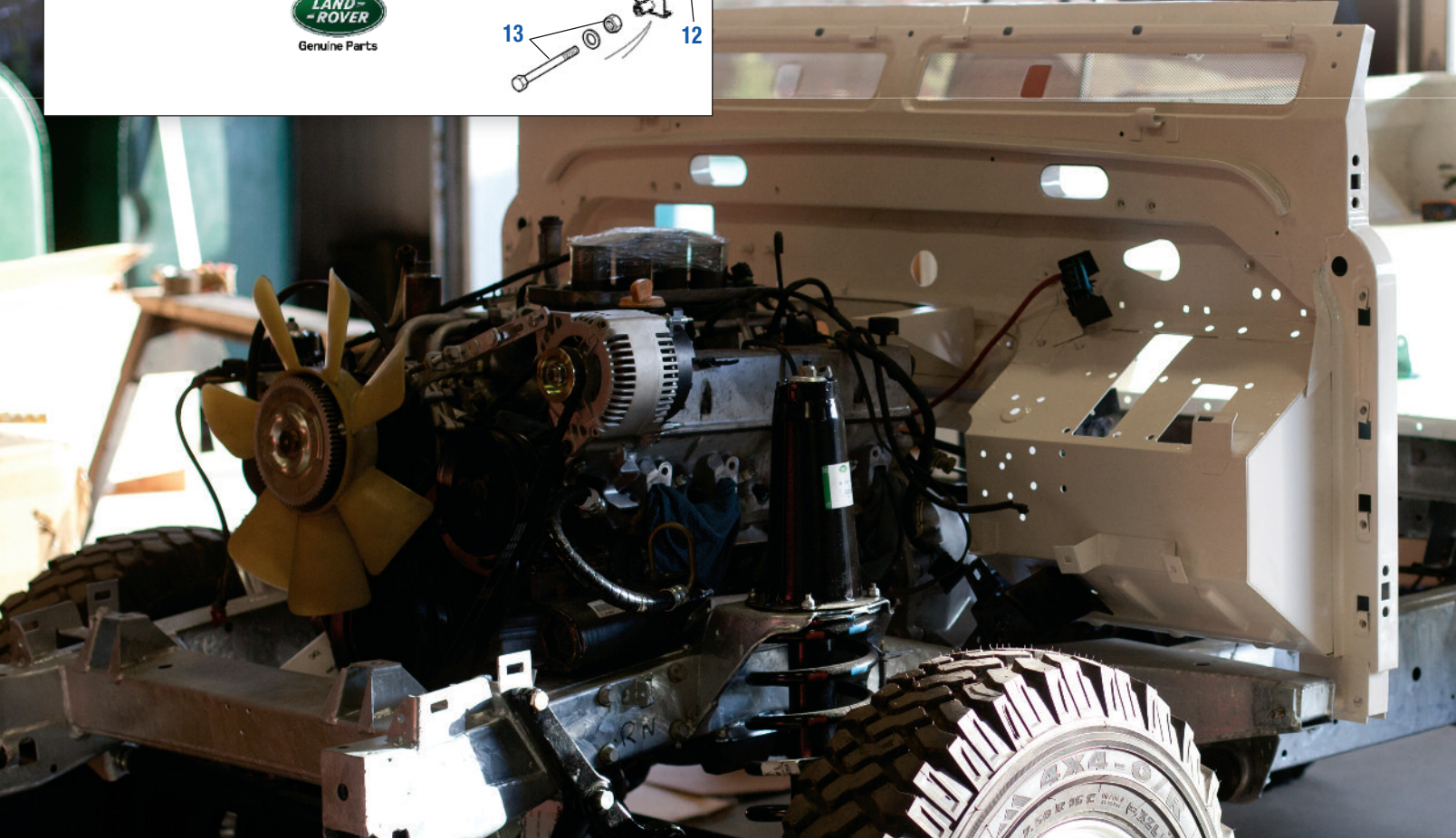

**B**

1  
RNF0012 LHF Outer

2  
RNF0014 LHF Inner

3

RNF0014 is required when fitting RNF0012

*\*All parts are galvanized except RNF0020 which is painted.*

**B Defender NAS 90, 110 Replacement Floor Footwell Panels**

Reproductions of exact factory units, these hand crafted 18 gauge steel units are galvanized\* and ready to fit into your Defender for a proper restoration.

1. Floor Panel, LHF Outer, 90/110 NAS, galvanized.....	RNF0012	\$ 69.95
Floor Panel, LHF Inner, 90/110 NAS, galvanized.....	RNF0014	\$ 45.95
Floor Panel, LHF Upper 90/110 NAS, galvanized.....	RNF0018	\$ 89.95
Floor Panel, RHF Inner 90/110 NAS, galvanized.....	RNF0015	\$ 45.95
Floor Panel, RHF Outer 90/110 NAS, galvanized.....	RNF0013	\$ 69.95
Floor Panel, RHF Upper 90/110 NAS, galvanized.....	RNF0019	\$ 79.95
2. Kick Panel, LHF Outer 90/110 NAS, galvanized.....	RNF0016	\$ 49.95
Kick Panel, RHF Outer 90/110 NAS, galvanized.....	RNF0017	\$ 49.95
3. Kick Panel, LHF Inner 90/110 NAS, painted steel.....	RNF0020	\$ 119.95
Kick Panel, RHF Inner 90/110 NAS, galvanized.....	RNF0021	\$ 69.95

**Defender Tunnel Panel**

**Center Bulkhead Lower**  
Weld in replacement piece for 90/110 NAS bulkheads.  
RNF0022 \$ 89.95



**Diaphragm Assembly Panel**  
3.5, 3.9 V8, 300 Tdi, Td5  
(see page 8 for illustration)  
RNN984 \$ 119.95

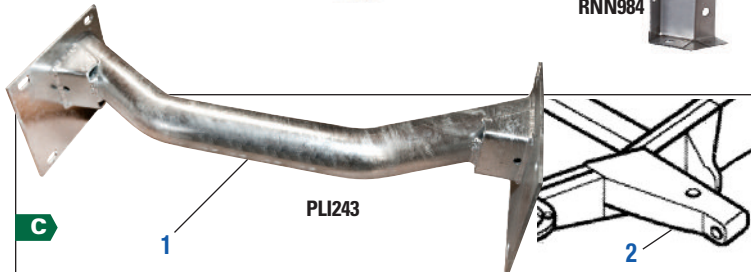

**C Defender Chassis Parts**

1. Crossmember Assembly NAS V-8 Galvanized, ProLine.....	PLI243	\$ 259.95
Crossmember Assembly from Tdi, Td5.....	RNI329	\$ 159.92
2. Bulkhead Outrigger RH, Genuine.....	RNI545	\$ 226.45
Bulkhead Outrigger RH, ProLine.....	PLI545	\$ 89.95
Bulkhead Outrigger LH, Genuine.....	RNI546	\$ 221.34
Bulkhead Outrigger LH, ProLine.....	PLI546	\$ 89.96

**Rear Chassis Cross-Member Replacement parts**

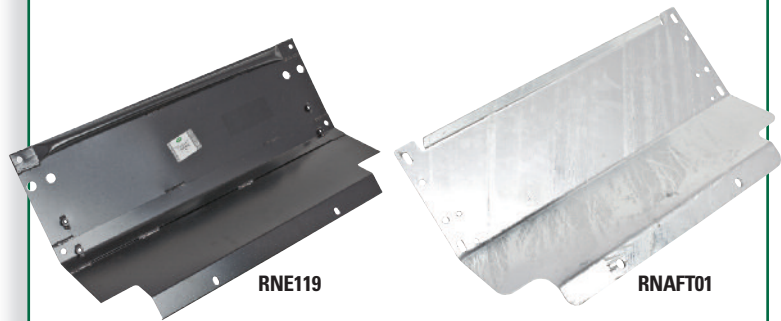
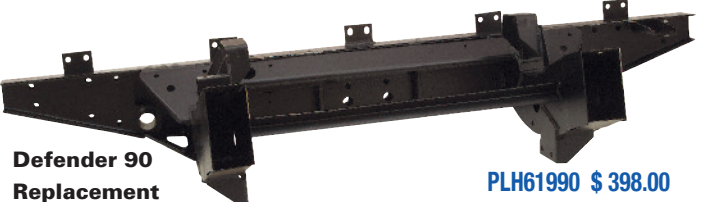
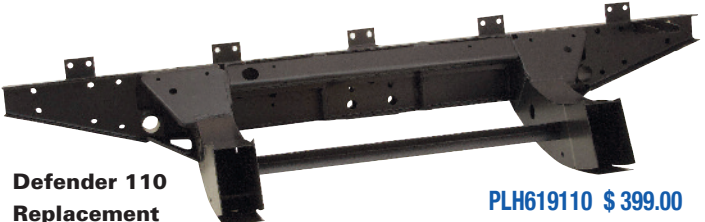
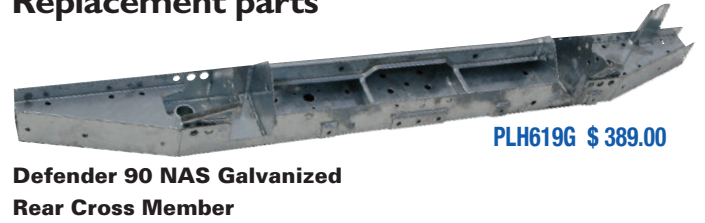

**Hot Dipped Galvanized Rear Cross Member**

Defender 90 NAS .....PLH619G \$ 389.00

**Replacement Cross Member**

Defender 110, Black non-galvanized (18" extension).....PLH619110 \$ 399.00

Defender 90, Black non-galvanized (18" extension).....PLH61990 \$ 398.00

**Hot Dipped Galvanized Fuel Tank Guard**

Galvanized skid plate. Replaces original sheet metal cradle, sold with hardware.

Defender 90 NAS .....RNAFT01 \$ 286.00

**Genuine Fuel Tank Cradle**

Defender 90 Fuel Tank Cradle (not a guard), Genuine .....RNE119 \$ 299.95



**Replacement chassis parts**

Welding is required to install these parts and should be referred to a professional. For the do-it-yourself Land Rover owner the job requires a cut off wheel and/or torch, 4" grinder and a 60 amp welder. Try 3/32" 6011 rods at 60 amps (45 amps DC) for best results.

# Seatbase - DEFENDER

## A Defender Seatbase

1. Front Main Floor Panel, RH LT 85 V8 Petrol .....	RNS299	\$ 163.43
Front Main Floor Panel, RH LT 77 2.5L 4CYL, 5CYL TDI .....	RNS300	\$ POA
2. Front Main Floor Panel, LH LT 85 V8 Petrol.....	RNS301	\$ 222.66
Front Main Floor Panel, LH LT 77 2.5L 4CYL, 5CYL TDI.....	RNS302	\$ 163.43
Front Main Floor Panel, LH 4CYL Petrol, 2.5L NA Diesel.....	RNS303	\$ 23.26
Floor Screw Kit, Defender 90, V8 .....	RNK890	\$ 169.95
Floor Screw Kit, Defender 110, V8 .....	RNK8110	\$ 139.95
3. Self Tapping Screw up to #3A654045.....	RNH042	\$ 1.95
Self Tapping Screw from #3A654046.....	RNS304	\$ 2.64
4. Plain Washer 6M .....	RNN986	\$ 0.85
5. Lokut Nut .....	RNC946	\$ 1.49
6. Screw M6x20MM .....	RNH483	\$ 0.49
7. Washer M6 .....	RNF420	\$ 1.49
8. Sprung Washer M6 .....	RNF428	\$ 2.34
9. Hex Nut M6 .....	RNF731	\$ 0.95
10. Bolt up to #3A654045.....	RNB701	\$ 1.59
Bolt from #3A654046 .....	RNS304	\$ 2.64
11. Washer M6 .....	RNF420	\$ 1.49
12. Spiralok Nut 110.....	RNS305	\$ 2.14
Spire Nut 90.....	RNB681	\$ 1.59
13. Seal - Cut to Length.....	RNN985	\$ 12.06

## Defender Tunnel Panel

14. Diaphragm Assembly Panel 2.3, 2.5L, 200 Tdi (shown) .....	RNN983	\$ POA
Diaphragm Assembly Panel 3.5, 3.9 V8, 300 Tdi, Td5.....	RNN984	\$ 119.95
15. Seal.....	RNN985	\$ 12.06
16. Self Tapping Screw.....	RNH042	\$ 1.95
17. Plain Washer 6M .....	RNN986	\$ 0.85
18. Tunnel Assembly.....	RNN987	\$ 312.27
19. Self Adhesive Packing Strip - Cut to Length.....	RNN988	\$ 28.64
20. Loknut Nut.....	RNC946	\$ 1.49
21. Transfer Case Cover, V8 (part of seatbox on R380).....	RNN989	\$ POA
22. Flanged Head Screw M8x20MM.....	RND942	\$ 1.59
23. Washer.....	RNX034	\$ 1.39
24. Sprung Washer M8 .....	RNF428	\$ 2.34
25. Hex Nut M8.....	RNE157	\$ 0.95
26. Gear Lever Assembly Gaiter - less EFI.....	RNH417	\$ 49.95
Gear Lever Assembly Gaiter - with EFI.....	RNN990	\$ 76.17
27. Cable Tie.....	RNN991	\$ 14.52
28. Insulation Pad 4 Cylinder .....	RNN992	\$ 60.74
Insulation Pad V8 .....	RNN993	\$ 66.91

## Defender Seatbase Assembly

29. Center Seatbase Lid Assembly w/o tunnel Consol up to 2007 .....	RNS315	\$ 71.63
Center Seatbase Lid Assembly w/tunnel Consol up to 2007 .....	RNS316	\$ 63.87
Center Seatbase Lid Assembly From 2007 on .....	RNS317	\$ 53.99
30. Battery Compartment Lid.....	RNS318	\$ 47.36
31. Locker Lid for Vehicles for Vehicles w/Additional Fuel Tanks from #HA455946 TO #LA932671 .....	RNS319	\$ 58.86
Locker Lid for Vehicles w/Additional Fuel Tanks from #LA932672 .....	RNS320	\$ 244.30
Locker Lid for Vehicles w/o Additional Fuel Tanks up to #WA159806.....	RNS321	\$ 204.67
Locker Lid Assembly from #XA159807 .....	RNS322	\$ 58.86
32. Self Taping Screw .....	RNC946	\$ 0.64
33. Washer M6 .....	RNF420	\$ 1.49
34. Spiralok Nut .....	RNS323	\$ 0.85
35. Rear Seat Stop to #HA455945.....	RNS324	\$ 55.81
Rear Seat Stop from #HA455946 .....	RNS325	\$ 12.02
36. Overcenter Catch.....	RNS326	\$ 14.31
37. Pop Rivet .....	RNS327	\$ 1.56
38. Blanking Plug 13MM.....	RNB875	\$ 0.48
Blanking Plug 50MM.....	RNB883	\$ 1.79
Blanking Plug 14MM.....	RNB876	\$ 0.75
Blanking Plug 30MM.....	RNN686	\$ 2.98
Blanking Plug 25.5MM.....	RNB880	\$ 1.59
39. Plate - Right Hand Drive V-8 .....	RNS328	\$ 111.37
40. Pop Rivet .....	RNC690	\$ 0.95
41. Extension Panel RH up to #HA455945.....	RNS329	\$ POA
Extension Panel LH up to #HA455945.....	RNS330	\$ POA

## A

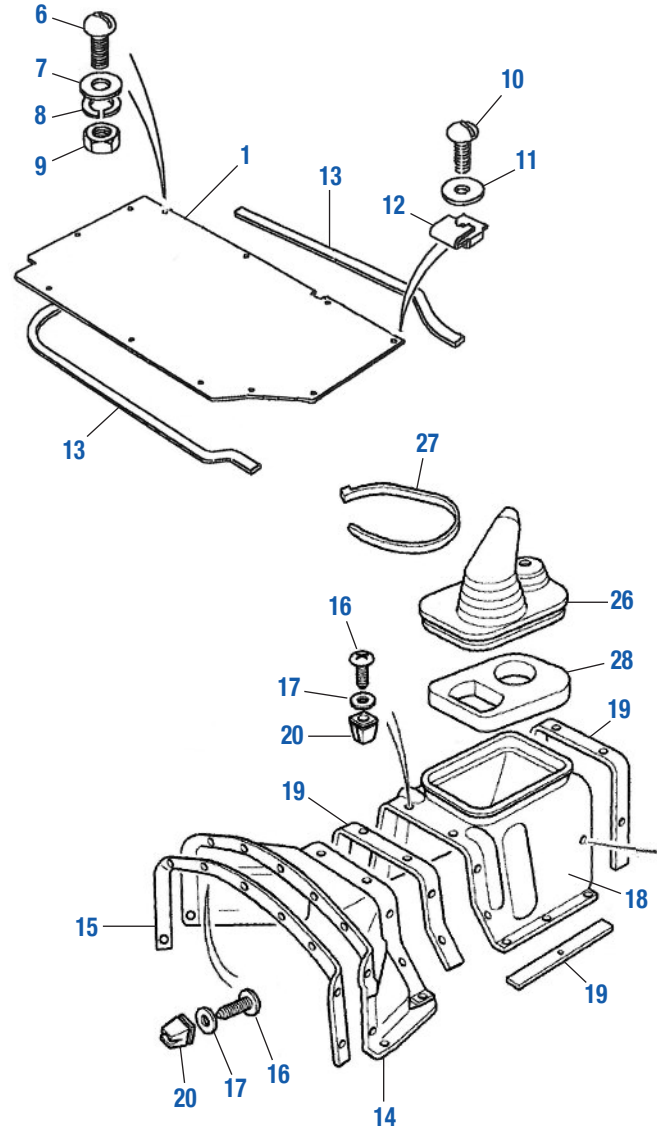

42. Screw M6.....	RND909	\$ 1.00
43. Plain Washer .....	RNI804	\$ 0.90
44. Spring Washer M6.....	RNF428	\$ 2.34
45. Hex Nut M6 up to 2007.....	RNF731	\$ 0.95
Flange Nut from 2007 on.....	RNS331	\$ 1.93
46. Blanking Plug from 2002 on .....	RNN785	\$ 4.61
47. Hex Nut 5M 1996 - 2006.....	RNI217	\$ 0.75
Flange Nut from 2007 on.....	RNS332	\$ 1.56
48. Gasket 1996 - 2006.....	RNS333	\$ 7.93
49. Stud 1996 - 2006.....	RNS334	\$ 11.89
50. Flange Nut M6 1996 - 2006 .....	RND756	\$ 1.59
51. Immobiliser Housing Box 1996 - 2006 .....	RNS335	\$ 37.85
52. Immobiliser Box Lid 1996 - 2006.....	RNS336	\$ 41.94
53. Monobolt.....	RNS337	\$ 4.09



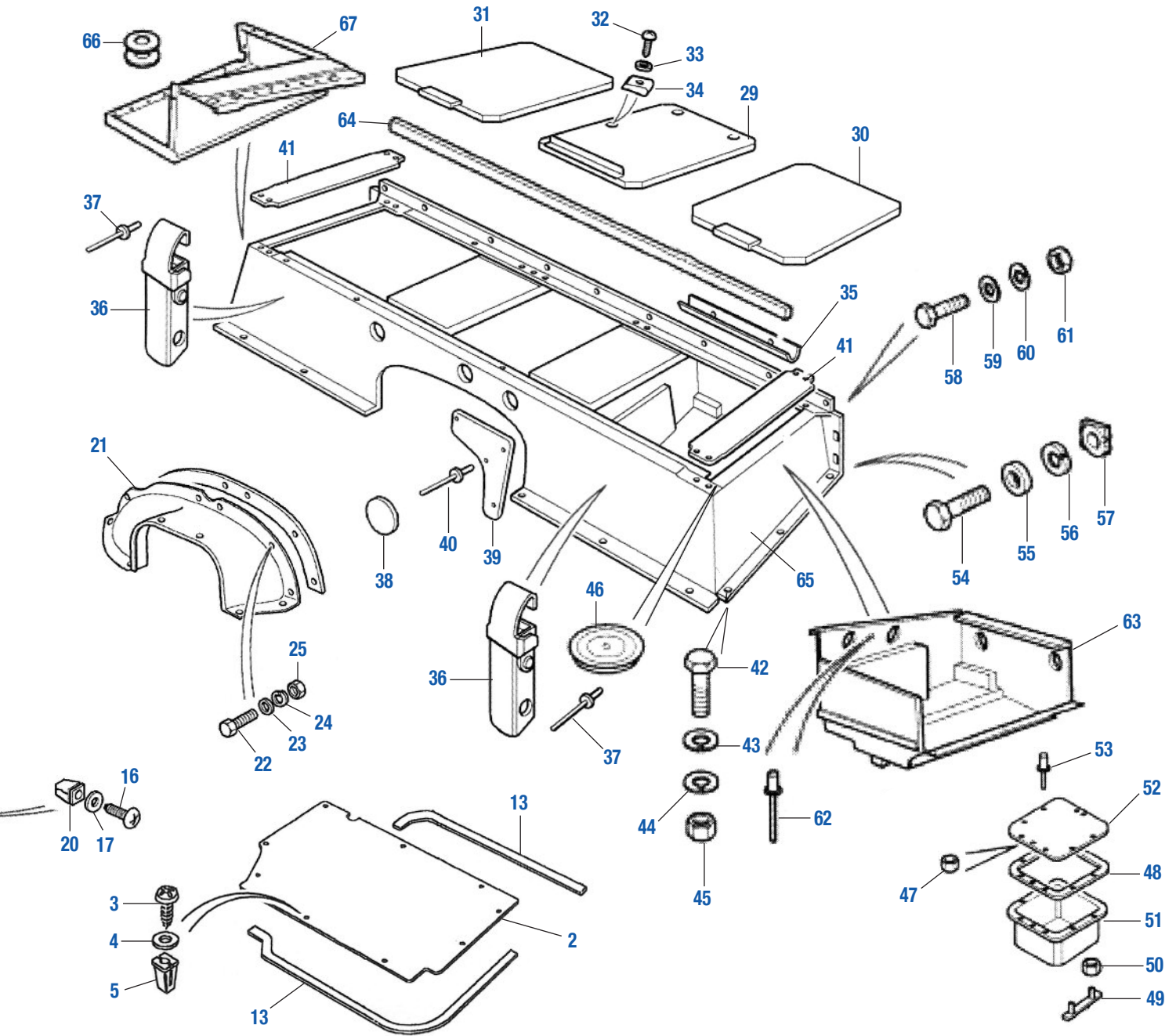

54. Screw M6x20MM .....	RND909	\$ 1.00
Screw M6x25MM .....	RND758	\$ 1.95
55. Plain Washer .....	RNF434	\$ 0.44
56. Washer - Spring M6.....	RNF428	\$ 2.34
57. Lokut Nut .....	RNS338	\$ 2.14
58. Screw M6x20MM .....	RND909	\$ 1.00
59. Washer.....	RNI804	\$ 0.90
60. Spring Washer M6.....	RNF428	\$ 2.34
61. Hex Nut M6.....	RNF731	\$ 0.95
62. Pop Rivet .....	RNC690	\$ 0.95
63. Battery Tray up to #WA159806 .....	RNS339	\$ 967.08
Battery Tray from #XA159807 .....	RNS340	\$ 95.55
64. Seal.....	RNN985	\$ 12.06

65. Seatbase Assembly with Left Hand Battery Box for vehicles with side fuel tank		
4 Cylinder models up to 1999 .....	RNS344	\$ 2899.00
V8.....	RNS346	\$ 3016.71
Seatbase Assembly with Left Hand Battery Box and Right Hand Tool Box		
for vehicles with rear fuel tank		
V8, Tdi.....	RNS349	\$ 436.89
Td5.....	RNS348	\$ 3167.39
Puma.....	RNS349	\$ 436.89
66. Harness Grommet.....	RNS352	\$ 20.44
67. Tool Box Assembly 90 4.0L V8 .....	RNS353	\$ 164.78
Tool Box Assembly from #XA159807 .....	RNS354	\$ 33.73

# Front Suspension

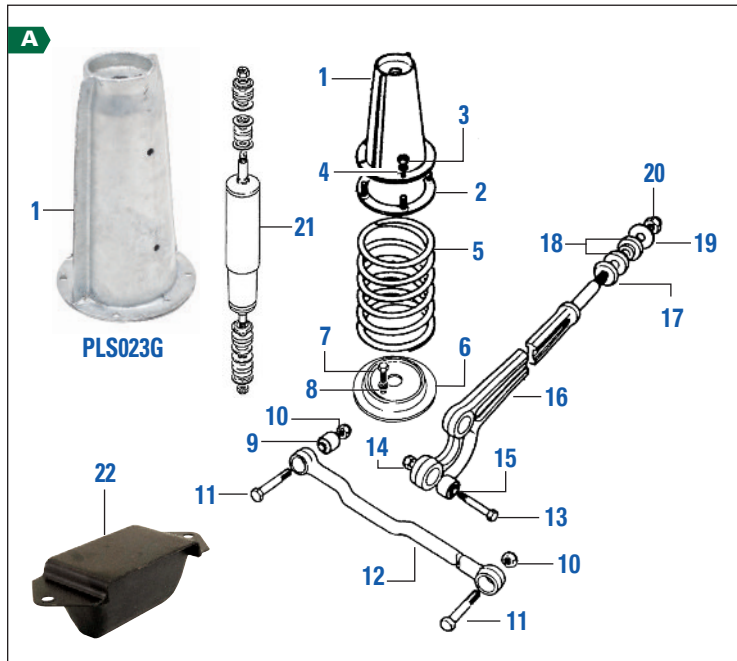

## A Front Suspension, LHD

1. **Shock Tower**, Defender, Genuine .....RNS023 \$ 84.95  
Shock Tower, Defender, Galvanized, ProLine ..... PLS023G \$ 49.50
2. **Securing Ring** for Shock Tower, Genuine, each.....RNS039 \$ 25.95  
Securing Ring for Shock Tower, HD, Terraforma, pair incl. nuts .....TF502 \$ 36.00
3. **Nut** (4 per ring required), Genuine.....RNS034 \$ 1.59
4. **Locker** for nut (4 per ring required), Genuine .....RNS037 \$ 0.59

### Front Coil Springs, Drivers Side

5. **Defender 90 Standard**, Genuine .....RNE444 \$ 69.95  
Defender 90 Heavy Duty, Genuine.....RNS046 \$ 69.95  
Defender 110 Standard, Genuine.....RNS050 \$ 69.95  
Defender 110 Standard, Proline ..... PLS050 \$ 49.95  
Defender 110 Heavy Duty, Genuine.....RNS046 \$ 69.95

### Front Coil Springs, Passenger Side

6. **Spring Seat**, Defender, Road Spring Seat, Genuine .....RNH058 \$ 19.95  
Road Spring Seat, Proline.....PLH058 \$ 10.80
7. **Bolt** M10 x 25mm (2 required per road spring seat), Genuine .....RNH059 \$ 0.98
8. **Lock Washer**, Genuine .....RNH011 \$ 1.49
9. **Bushing** for Panhard Rod, Defender, Genuine .....RNS049 \$ 13.95
10. **Lock Nut** - Defender, Genuine.....RNS058 \$ 3.28
11. **Bolt** for Panhard Rod to axle bracket, Genuine .....RNS052 \$ 7.95
12. **Panhard Rod Assembly** with Bushings, Defender, Genuine .....RNS024 \$ 229.95
13. **Bolt**, Radius Arm to Axle, Defender, Genuine.....RNC911 \$ 5.95
14. **Lock Nut** for Radius Arm Bolt, Genuine .....RNS031 \$ 2.95

### Bushing for Radius Arm

15. **Defender** up to '94, Genuine .....RNE467 \$ 26.95  
Defender '94 on, Genuine .....RNS060 \$ 17.95

### Front Radius Arm Assembly w/ Front Axle Bushings

16. **Defender** up to '94, Genuine .....RNE456 \$ 499.95  
Defender '94 on, Genuine .....RNH056 \$ 389.95
17. **Dished Washer**, Genuine.....RNS029 \$ 4.65
18. **Bushing Set**, Front Radius Arm to Chassis, Genuine.....RNS028 \$ 5.95
19. **Flat Washer**, Genuine.....RNS027 \$ 9.80
20. **Lock Nut**, Genuine.....RNS026 \$ 9.95
21. **Front Shock Absorber** w/bushings, Defender 90, Genuine .....RNF336 \$ 119.25  
Front Shock Absorber w/bushings, Defender 110, Genuine .....RNF338 \$ 99.95
22. **Front Axle Stops**, Defender, Genuine.....RNC879 \$ 28.50  
Front Axle Stops, Defender, ProLine .....PLC879 \$ 9.95

**LAND-ROVER**  
Genuine Parts

**Superior Performance  
Variable Rate Springs**

**Land Rover Genuine Coil Spring Kits**  
 Defender 90, Coil Spring Set of Four, HD w/winch, Genuine .....RNK5111 \$ 325.44  
 Defender 90, Coil Spring Set of Four, Heavy Duty, Genuine.....RNK5101 \$ 285.00  
 Defender 110, Coil Spring Set of Four, HD, Genuine .....RNK5102 \$ 278.19

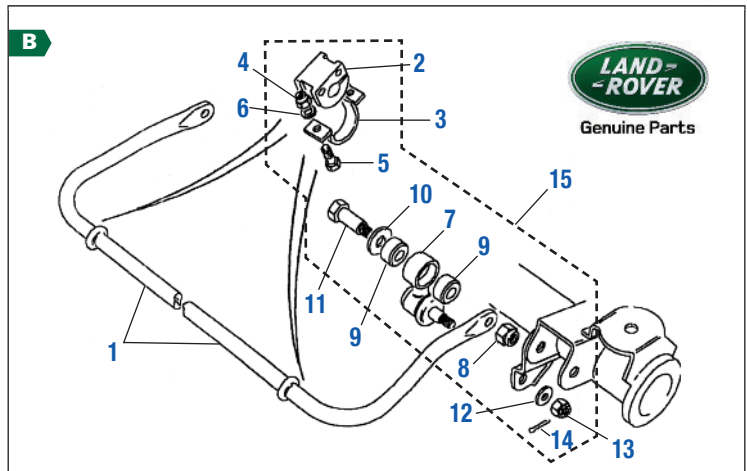

## B Land Rover Genuine Front Suspension - Anti-Roll Bar

1. **Anti-roll bar** .....RNS481 \$ 199.95
2. **Bushing** .....RN1868 \$ 14.91
3. **Sway Bar Mounting Bracket** .....RNS119 \$ 10.95
4. **Nyloc Nut** M10 .....RNE470 \$ 1.79
5. **Bolt** M10 x 35mm .....RNS482 \$ 4.56
6. **Plain Washer** 10mm I.D. ....RNF416 \$ 0.95
7. **Ball Joint** .....RNS124 \$ 74.95
8. **Lock Nut** M16 .....RNH045 \$ 1.19
9. **Shock Bushing** .....RNS115 \$ 3.08
10. **Plain Washer** .....RNH041 \$ 1.75
11. **Pin** .....RNH050 \$ 23.72
12. **Plain Washer** M12 x 28mm OD .....RNH055 \$ 0.50
13. **Castle Nut** 12mm .....RNH037 \$ 3.95
14. **Split Pin** .....RNS483 \$ 0.85
15. **Complete Anti-Roll Bar Kit** .....RNK4235 \$ 272.81

## C Land Rover Genuine Rear Suspension, LHD

- LAND-ROVER**  
Genuine Parts
1. **Rear Springs, Drivers Side**  
 Defender 90 Standard .....RNS046 \$ 69.95  
 Defender 90 Heavy Duty .....RNE526 \$ 97.95  
 Defender 110 Standard.....RNE431 \$ 79.95  
 Defender 110 Heavy Duty .....RNE432 \$ 69.95
  - Rear Springs, Passenger Side**  
 Defender 90 Standard .....RNS047 \$ 69.95  
 Defender 90 Heavy Duty .....RNE527 \$ 97.95  
 Defender 110 Standard.....RNE438 \$ 119.95  
 Defender 110 Heavy Duty .....RNE436 \$ 69.95
  2. **Spring Retainer**, Defender 90.....RNH061 \$ 5.95  
 Spring Retainer, Defender 110 .....RN1518 \$ 5.95

3. <b>Spring Seat</b> , Defender 90, Genuine.....	RNH058	\$ 19.95
Spring Seat, Defender 90, ProLine.....	PLH058	\$ 10.80
Spring Seat, Defender 110, Genuine.....	RNI519	\$ 18.50
4. <b>Bolt for Spring Retainer</b> , Defender 90/110, Genuine.....	RNH059	\$ 0.98
5. <b>Lock Washer</b> , Defender, Genuine.....	RNH060	\$ 0.59
6. <b>Flat Washer</b> , Defender, Genuine.....	RNF416	\$ 0.95
7. <b>Spring Seat Isolator</b> , will fit Defenders.....	RND736	\$ 21.95

**Shock Mounting Hardware**

8. <b>Shock Bushing</b> , Defender, Genuine.....	RNE423	\$ 11.95
9. <b>Bushings</b> , Defender, Genuine.....	RNI521	\$ 3.95
10. <b>Washer</b> , Defender, Genuine.....	RND092	\$ 0.90
11. <b>Washer</b> , Defender 90/110, Genuine.....	RNI522	\$ 4.95
12. <b>Lock Nut</b> , Defender, Genuine.....	RNI524	\$ 1.78
13. <b>Shock Mount Bracket</b> , Defender, Genuine.....	RNH617	\$ 106.67
14. <b>Bolt</b> , Defender, Genuine.....	RNI525	\$ 6.75
15. <b>Lock Washer</b> , Defender, Genuine.....	RNH060	\$ 0.59
16. <b>Flat Washer</b> , Defender, Genuine.....	RNF746	\$ 0.59
17. <b>Nut</b> , Defender 110, Genuine.....	RNI526	\$ 3.69
Nut, Defender 90, Genuine.....	RNE158	\$ 0.66
18. <b>Inner Shock Mount Retainer</b> , Defender, Genuine.....	RNI527	\$ 8.95
19. <b>Outer Shock Mount Retainer</b> , Defender, Genuine.....	RNI528	\$ 4.21
20. <b>Nyloc Nut</b> , Defender, Genuine.....	RNE471	\$ 1.79
21. <b>Rear Shock Absorber</b> w/ bushings, Defender 90, Genuine.....	RNF337	\$ 119.25
Rear Shock Absorber w/ bushings, Defender 110, Standard.....	RNF339	\$ 98.95
Rear Shock Absorber w/ bushings, Defender 110, Heavy Duty.....	RNF180	\$ 109.45

**Bottom Link Assembly**

22. <b>Defender</b> , includes rear bushing, Genuine.....	RNS038	\$ 88.90
23. <b>Lock Nut</b> , Genuine.....	RNS026	\$ 9.95
24. <b>Flat Washer</b> , Genuine.....	RNS032	\$ 2.38
25. <b>Bushing Kit</b> , supplied as vehicle set, incl. left+right, Genuine.....	RNS033	\$ 64.95
Bushing Kit, supplied as vehicle set, incl. left+right, ProLine.....	PLS033	\$ 10.50
26. <b>Bushing</b> , Bottom Link to Rear Axle, Genuine.....	RNS040	\$ 14.95
27. <b>Bolt</b> , Bottom Link to Axle, Genuine.....	RNS030	\$ 7.59
28. <b>Lock Nut</b> , Genuine.....	RNS031	\$ 2.95

**Top Link Components**

27. <b>Ball Joint Assembly</b> , attaches top link to rear axle, Genuine.....	RNS072	\$ 65.95
28. <b>Nut</b> for Top Link Bolt, Genuine.....	RND300	\$ 3.59
29. <b>Bushing</b> for Top Link, Genuine.....	RNS067	\$ 19.95
30. <b>Bolt</b> for Top Link, Genuine.....	RNS068	\$ 14.95
31. <b>Ball Joint Leveling Unit</b> , Defender 110, w/coil spring suspension, (2 required), Genuine.....	RNS112	\$ 39.50
33. <b>Rear Axle Stops</b> , Defender, Genuine.....	RNC879	\$ 28.50
Rear Axle Stops, Defender, ProLine.....	PLC879	\$ 9.95

34. <b>Anti-Roll Bar</b> , Defender 90/110, new style to compliment plastic fuel tank, up to 2007.....	RNH357	\$ 139.95
35. <b>Bushing</b> , Defender 90.....	RNH358	\$ 5.95
Bushing, Defender 110.....	RNH359	\$ 8.63
36. <b>Bracket</b> , Defender 90.....	RNS484	\$ 32.35
Bracket, Defender 110.....	RNS529	\$ 16.45
37. <b>Bolt</b> 8m x 25mm.....	RNN343	\$ 0.95
38. <b>Washer Flat</b> 8mm I.D., Defender 90.....	RNF548	\$ 0.69
Washer Flat 8mm I.D., Defender 110.....	RNI121	\$ 0.75
39. <b>Spring Washer</b> M8, Defender 110 only.....	RNF429	\$ 0.65
40. <b>Nyloc Nut</b> M8, Defender 90.....	RNE469	\$ 0.95
Flange Nut M8, Defender 110.....	RNE157	\$ 0.95
41. <b>Ball Joint</b> .....	RNS124	\$ 74.95
42. <b>Plain Washer</b> M12 x 28mm O.D.....	RNH055	\$ 0.50
Plain Washer M12.....	RNF417	\$ 1.79
43. <b>Castle Nut</b> 12mm.....	RNH037	\$ 3.95
44. <b>Split Pin</b> .....	RNS483	\$ 0.85
45. <b>Sway Bar Pivot Pin</b> .....	RNS530	\$ 7.83
46. <b>Washer Plain</b> .....	RNH041	\$ 1.75
47. <b>Shock Bushing</b> .....	RNS115	\$ 3.08
48. <b>Plain Washer</b> 16mm I.D.....	RNH043	\$ 2.59
49. <b>Lock Nut</b> M16, Defender 90.....	RNH045	\$ 1.19
Nyloc Nut M16, Defender 110.....	RNE473	\$ 3.95
50. <b>Mounting Kit</b> , Defender 90.....	RNK4236	\$ 283.72
Mounting Kit, Defender 110.....	RNK4237	\$ 244.65

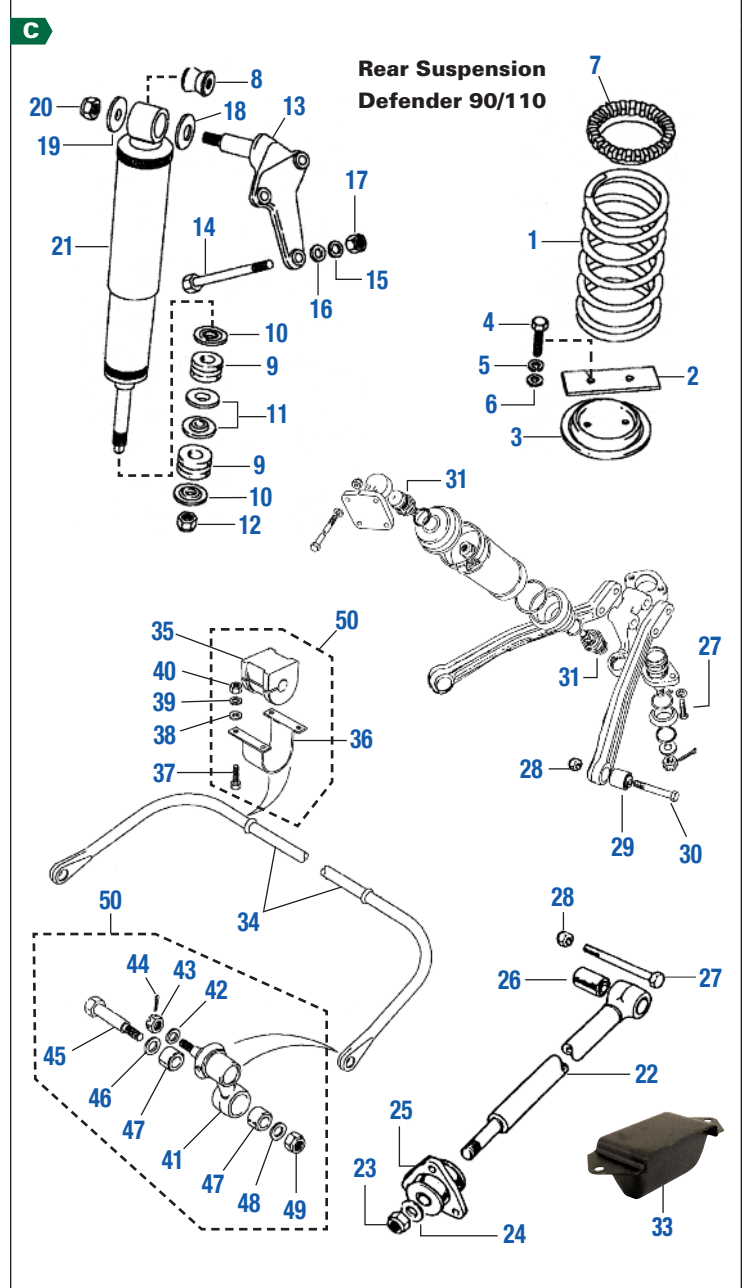



**Genuine Suspension Bushing Kits**

**Front Axle Bushing Kits**

Suspension Bushing Kit, Front, Defender up to 1994.....**RNK5910 \$ 169.00**

Suspension Bushing Kit, Front, Defender 1994 on.....**RNK5916 \$ 183.60**

**Rear Axle Bushing Kits**

Suspension Bushing Kit, Rear, Defender.....**RNK5915 \$ 223.00**

# Suspension Kits – DEFENDER

## Old Man Emu Heavy Duty Springs & Shock Kits



Ideal for owners using oversize tires combined with heavy duty bumper/winch combinations and extra vehicle equipment. Designed for heavy duty off-road use. Will raise vehicle approximately 1 inch. Great off-road, fair on-road. Includes 4 OME Nitro Charger Sport Shocks & 4 OME springs. Imported from Australia. Standard Length.



<b>Defender 90</b>		
Defender 90 1984-2002, Standard Duty.....	OMED90K1	\$ 769.00
Defender 90 1984-2002, Heavy Duty .....	OMED90K2	\$ 769.00
Steering Damper .....	OMESD32	\$ 94.50
<b>Defender 110</b>		
Defender 110 Station Wagon 1983-2002, Standard Duty.....	OMED110K1	\$ 749.00
Defender 110 Station Wagon 1983-2002, Heavy Duty .....	OMED110K2	\$ 769.00
Steering Damper .....	OMESD32	\$ 94.50
<b>Defender Pick Up or Hardtop</b>		
Defender Pick Up or Hardtop 1983-2002, Standard Duty.....	OMED110RK1	\$ 769.00
Defender Pick Up or Hardtop 1983-2002, Heavy Duty .....	OMED110RK2	\$ 749.00
Steering Damper .....	OMESD32	\$ 94.50

## Terraforma Pro Sport +2 inch Heavy Duty Suspension Kits

Include; 4 Terraforma +2 inch Pro Sport shocks and 4 +2 inch springs. Great off-road, excellent on-road.



<b>Defender 90, 1984-'02, Terraforma Pro Sport HD Suspension Kit.....</b>	<b>RNK725</b>	<b>\$ 599.00</b>
<b>Defender 110, 1983-'02, Terraforma Pro Sport HD Suspension Kit.....</b>	<b>RNK727</b>	<b>\$ 629.00</b>

## Britpart Heavy Duty Springs & Pro Comp +2 inch Shock Kits

Designed for owners who want the most suspension lift possible without modifications. A true 2 inch taller spring and shock kit. Ideal for owners using oversize tires combined with heavy duty bumper/winch combinations and extra vehicle equipment. Designed for all round use. Great off-road, excellent on-road. Includes 4 Pro Comp Nitrogen Charged + 2 inch shocks & ProLine springs. Springs imported from England - shocks made in the USA.



<b>Defender 90 1984-2002, Standard Duty .....</b>	<b>RNK450</b>	<b>\$ 499.00</b>
<b>Defender 90 1984-2002, Heavy Duty .....</b>	<b>RNK451</b>	<b>\$ 499.00</b>
<b>Defender 110 1983-2002, Heavy Duty.....</b>	<b>RNK452</b>	<b>\$ 499.00</b>



## Land Rover Heavy Duty Coil Springs and Bilstein Shock Kits Superior Performance Variable Rate Springs



<b>Land Rover Genuine Springs &amp; Bilstein Shocks. Kits include front and rear shocks.</b>		
<b>Defender 90, Land Rover HD Springs &amp; Bilstein Shocks.....</b>	<b>RNK5201</b>	<b>\$ 599.90</b>
<b>Defender 110, Land Rover HD Springs &amp; Bilstein Shocks.....</b>	<b>RNK5202</b>	<b>\$ 599.00</b>
<b>Defender 90, w/winch, LR HD springs &amp; Bilstein Shocks.....</b>	<b>RNK5211</b>	<b>\$ 679.00</b>

1/2 kit shown

### Defender 110, 130 Rear Heavy Duty Inner Coil Spring Kit

Update your Defender 110 or 130 to the ultimate heavy duty rear suspension. This inner coil kit inserts into your existing heavy duty rear springs. Improves handling on-road and increases load capacity without the harsh ride. **Kit contains two rear inner coils, upper and lower retainers, Genuine parts. Fits Defender 110, 130 only. RNK5119 \$ 499.00**

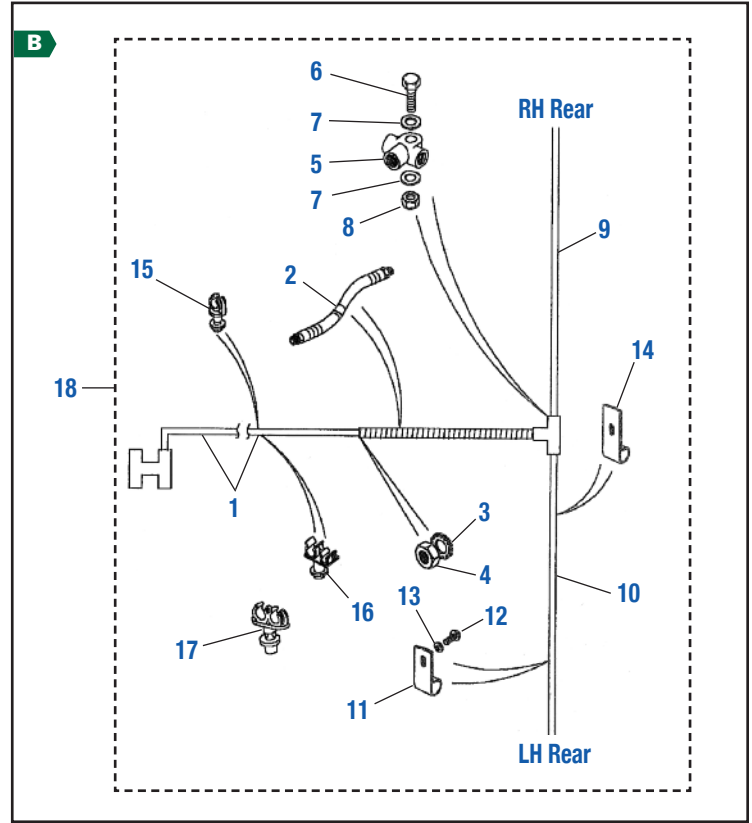
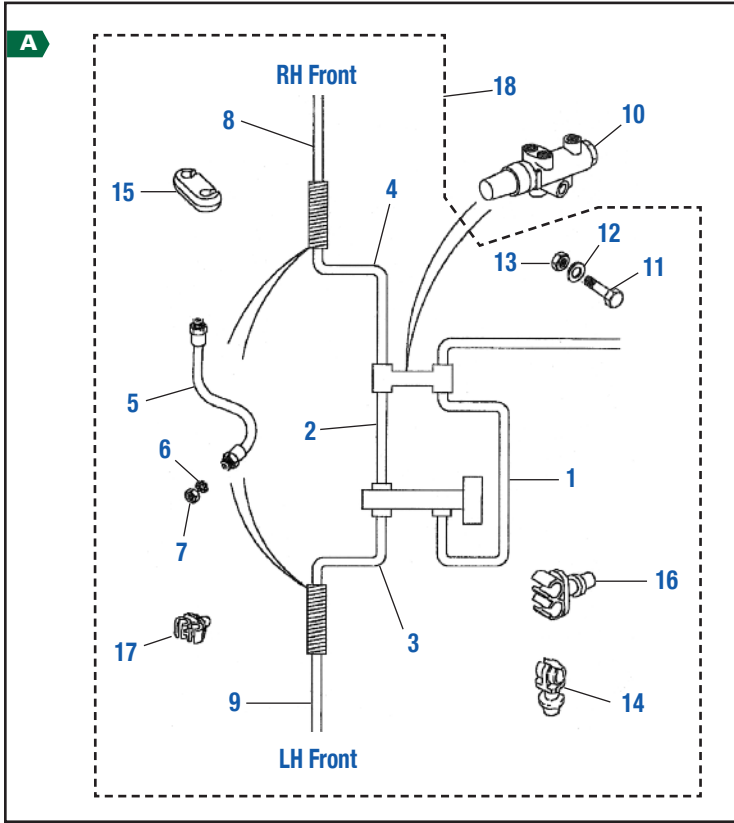

## A Defender 90 Front Brake Pipes

1. Brake Pipe: Master-Valve.....	RNS493	\$ 26.09
2. Brake Pipe: Master-Valve.....	RNS494	\$ 60.30
3. Brake Pipe: Right Hand Front.....	RNS495	\$ 32.37
4. Brake Pipe: Left Hand Front.....	RNS496	\$ 154.34
5. Flex Hose.....	RNL407	\$ 71.61
6. Lock Washer 10mm I.D.....	RNS497	\$ 1.56
7. Lock Nut 10mm.....	RNS498	\$ 1.56
8. Brake Pipe: Brake-Caliper RH '94-'95.....	RNS499	\$ 111.03
Brake Pipe: Brake-Caliper RH '97.....	RNS500	\$ 71.61
9. Brake Pipe: Brake-Caliper LH '94-'95.....	RNS501	\$ 81.11
Brake Pipe: Brake-Caliper LH '97.....	RNS502	\$ 71.61
10. Brake Valve.....	RNH746	\$ 294.81
11. Flange Bolt M8 x 55mm.....	RNN430	\$ 3.60
12. Washer Flat 8mm I.D.....	RNI121	\$ 0.75
13. Nyloc Nut M8.....	RNE469	\$ 0.95
14. Single Brake Pipe Clip.....	RNI825	\$ 1.79
15. Double Brake Pipe Clip.....	RNS503	\$ 1.56
16. Double Brake Pipe Clip.....	RNS504	\$ 0.97
17. Double Brake Pipe Clip.....	RNS505	\$ 2.14
18. Complete Brake Pipe Kit '94-'95.....	RNK4226	\$ 582.21
Complete Brake Pipe Kit '97.....	RNK4227	\$ 520.07

## B Defender 90 Rear Brake Pipes

1. Brake Pipe: Valve-Rear.....	RNS506	\$ 103.99
2. Flex Hose.....	RNS507	\$ 71.61
3. Lock Washer 10mm I.D.....	RNS497	\$ 1.56
4. Lock Nut 10mm.....	RNS498	\$ 1.56
5. Brake Junction.....	RNS508	\$ 39.01
6. Bolt 6mm x 30mm.....	RNS509	\$ 1.82
7. Plain Washer 6mm I.D.....	RNX034	\$ 1.39
8. Nut M6.....	RND114	\$ 0.89
9. Brake Pipe RH.....	RNS510	\$ 146.34
10. Brake Pipe LH.....	RND997	\$ 124.76
11. Clip.....	RNS511	\$ 39.16
12. Screw.....	RNS512	\$ 0.85
13. Plain Washer.....	RNF421	\$ 0.44
14. Strap.....	RNA903	\$ 11.95
15. Single Clip.....	RNI825	\$ 1.79
16. Double Clip.....	RNS504	\$ 0.97
17. Double Clip.....	RNS513	\$ 1.56
18. Complete Brake Pipe Kit.....	RNK4228	\$ 510.58



Defender 90 Front Brake Flex Hose RNL407



Single Fuel Line Clip	Single Fuel Line Clip	Pipe Clip Single	Pipe Clip Double
RNS546	RNS548	RNS547	RNS504
\$ 0.85	\$ 4.86	\$ 1.56	\$ 0.97



## G Stainless Steel Brake Line Kits - DOT approved

These extended flexible stainless steel brake line kits are designed for Land Rovers with lifted suspension. Replaces your rubber flex lines. Equipped with factory fittings. No adapters required. Directions included.

Extended Length + 2" inch, Defender.....	SBL2003E	\$ 89.50
Extended Length + 4" inch, Defender.....	SBL2004E	\$ 89.50

# Brake Pipes – DEFENDER

## A 1993 Defender 110 NAS, LHD Front Brake Pipes

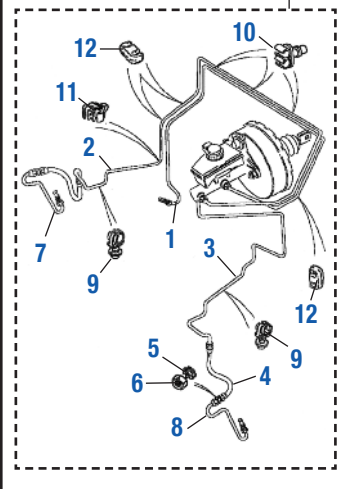

## B 1993 Defender 110 NAS, LHD Rear Brake Pipes

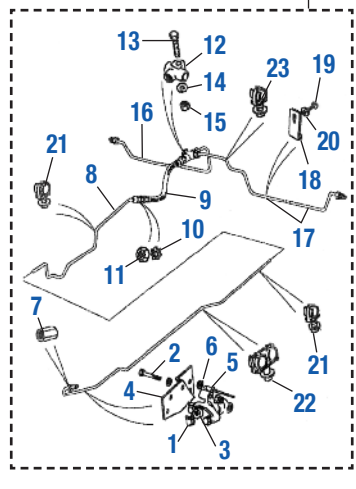

## A Defender 110 Front Brake Pipes

1. Brake Pipe-for Vehicles W/ G Valve.....	RNS531	\$ 49.32
Brake Pipe-for Vehicles W/ Connector .....	RNS532	\$ 263.08
2. Brake Pipe RH.....	RNS533	\$ 33.19
3. Brake Pipe LH.....	RNS496	\$ 154.34
4. Flex Hose.....	RNL407	\$ 71.61
5. Lock Washer 10mm I.D.....	RNS497	\$ 1.56
6. Lock Nut 10 mm.....	RNS498	\$ 1.56
7. Brake Pipe RH.....	RNS499	\$ 111.03
8. Brake Pipe LH.....	RNS501	\$ 81.11
9. Single Pipe Clip.....	RNI825	\$ 1.79
10. Double Pipe Clip.....	RNS504	\$ 0.97
11. Clip.....	RNS505	\$ 2.14
12. Dual Pipe Retainer.....	RNS503	\$ 1.56
13. Brake Pipe Kit for Vehicles w/G Valve.....	RNK4231	\$ 558.81
Brake Pipe Kit for Vehicles w/o G Valve.....	RNK4232	\$ 516.32

## B Defender 110 Rear Brake Pipes

1. G Valve.....	PLN971	\$ 429.95
2. Bolt.....	RNE083	\$ 1.59
3. Nyloc Nut M8.....	RNE469	\$ 0.95
4. Mounting Bracket.....	RNS534	\$ 83.52
5. Rivet.....	RNI307	\$ 0.85
6. Washer.....	RNA964	\$ 0.99
7. Connector.....	RNS535	\$ 7.78
8. Brake Pipe - For Vehicles Fitted W/G Valve .....	RNS536	\$ POA
Brake Pipe - For Vehicles Fitted W/Connector.....	RNS537	\$ 36.52
9. Flex Hose.....	RNL455	\$ 82.51
10. Lock Washer 10mm I.D.....	RNS497	\$ 1.56
11. Lock Nut 10mm.....	RNS498	\$ 1.56
12. Brake Junction.....	RNS508	\$ 39.01
13. Bolt 6mm x 30mm.....	RNS509	\$ 1.82
14. Plain Washer 6mm I.D.....	RNX034	\$ 1.39
15. Nut M6.....	RND114	\$ 0.89
16. Brake Pipe RH.....	RNS538	\$ 60.56
17. Brake Pipe LH.....	RNS539	\$ 71.61
18. Clip.....	RNS511	\$ 39.16
19. Drive Screw.....	RNS540	\$ 0.66
20. Washer.....	RNF421	\$ 0.44
21. Single Pipe Clip.....	RNI825	\$ 1.79
22. Double Pipe Clip.....	RNS504	\$ 0.97
23. Brake Pipe Kit for Vehicles w/G Valve.....	RNK4233	\$ 733.00
Brake Pipe Kit for Vehicles w/o G Valve.....	RNK4234	\$ 208.70

## C Defender Fuel Lines

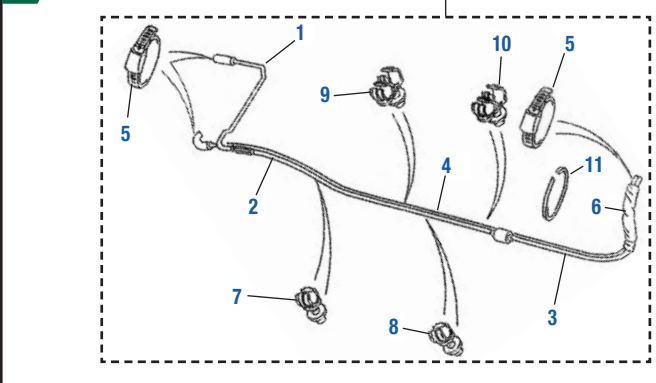

## C Defender Fuel Lines

1. Fuel Pipe: Pump-Junction, Defender 110.....	RNS541	\$ 57.80
2. Fuel Pipe: Filter-Engine, Defender 110.....	RNS542	\$ 450.51
Fuel Pipe: Tank-Filter, Defender 90 up to #VA106984.....	RNS550	\$ NLA
Fuel Pipe: Tank-Filter, Defender 90 from #VA106985.....	RNS551	\$ 187.50
3. Fuel Pipe: Filter-Injector, Defender 110.....	RNS543	\$ 93.15
Fuel Pipe: Filter-Engine, Defender 90.....	RNS552	\$ 171.00
4. Fuel Pipe: Spill Return, Defender 110.....	RND544	\$ 2.31
Fuel Pipe: Engine-Tank, Defender 90 up to #VA106984.....	RNS553	\$ POA
Fuel Pipe: Engine-Tank, Defender 90 from #VA106985.....	RNS554	\$ 330.44
5. Hose Clamp.....	RNC944	\$ 1.35
6. Fuel Pipe Sleeve.....	RNS545	\$ 14.32
7. Single Fuel Line Clip.....	RNS546	\$ 0.85
8. Single Fuel Line Clip.....	RNS547	\$ 1.56
9. Double Fuel Line Clip.....	RNS548	\$ 4.86
10. Double Fuel Line Clip, Defender 110.....	RNS549	\$ 1.11
Double Fuel Line Clip, Defender 90.....	RND912	\$ 3.95
11. Cable Tie.....	RNI171	\$ 1.95
12. Fuel Line Kit, Defender 110.....	RNK4296	\$ 656.54

## D Defender 90 Side Fuel Tank

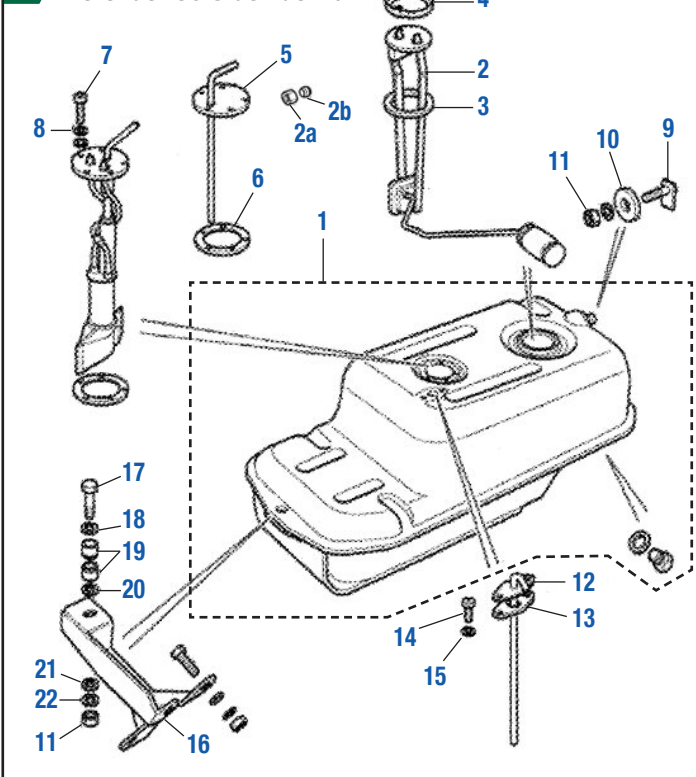

**E 1994, 1995, 1997  
Defender 90 NAS  
Fuel Pumps &  
Tanks**

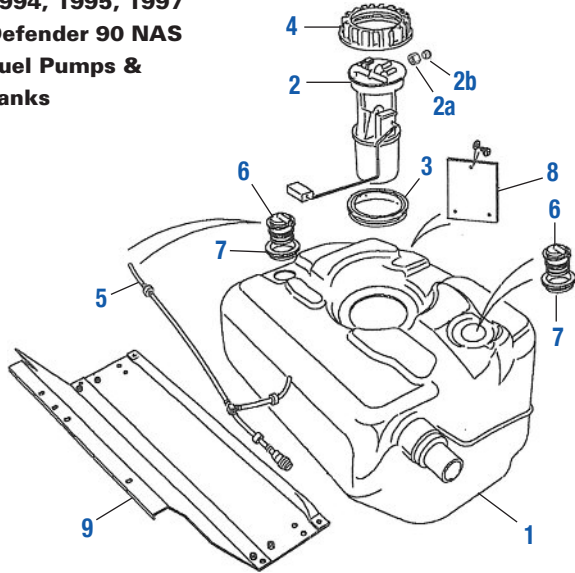

**E Defender 90 Fuel Tank**

1. Fuel Tank, Defender 90.....	RNE117	\$ POA
2. Pump & Sender Assembly, Defender 90, 1994-1997, Rear Tank NAS, Genuine.....	RNE131	\$ 359.00
2a. Union Nut (for attaching fuel line to pump) 2 required.....	RNF140	\$ 3.95
2b. Olive Fuel Feed (for attaching fuel lines to pump) 2 required.....	RNF136	\$ 1.95
3. Sealing Ring, Defender 90.....	RNF138	\$ 19.95
4. Fuel Sender Locking Ring, Defender 90.....	RNE464	\$ 9.95
5. Vent Piping.....	RNE120	\$ 299.95
6. Cut Off Valve.....	RNE461	\$ POA
7. Sealing Ring.....	RNE465	\$ 27.95
8. Heat Shield.....	RNN243	\$ 60.92
9. Cradle for Fuel Tank, Genuine.....	RNE119	\$ 299.95
Galvanized Cradle for Fuel Tank, Defender 90, ProLine.....	RNAFT01	\$ 286.00

**D Defender 90 Side Fuel Tank**

1. Side Fuel Tank, Defender 90.....	PLI135	\$ 295.00
2. Fuel Sender Unit, Diesel, Genuine.....	RNI774	\$ 189.95
Fuel Sender Unit, Diesel, ProLine.....	PLI774	\$ 42.90
2a. Union Nut (for attaching fuel line to pump) 2 required.....	RNF140	\$ 3.95
2b. Olive Fuel Feed (for attaching fuel lines to pump) 2 required.....	RNF136	\$ 1.95
3. Sealing Gasket.....	RNC887	\$ 2.95
4. Lock Ring.....	RNC886	\$ 4.99
5. Fuel Pipe, Diesel.....	RNS690	\$ 57.80
6. Sealing Gasket.....	RNF425	\$ 4.95
Sealing Ring, Proline.....	PLF425	\$ 1.25
7. Screw (uses qty 5).....	RNF264	\$ 1.49
8. Washer (uses qty 5).....	RNF415	\$ 1.79
9. Mounting Bolt (uses qty 2).....	RNS691	\$ 7.93
10. Washer.....	RNF548	\$ 0.69
11. Flange Nut.....	RNE157	\$ 0.95
12. Return Pipe, Diesel.....	RNS692	\$ 71.63
13. Sealing Gasket.....	RNE127	\$ 1.79
14. Screw.....	RNC131	\$ 4.95
15. Washer.....	RNB698	\$ 0.66
16. Front Mount.....	RNS693	\$ 129.01
17. Mounting Bolt.....	RNS694	\$ 23.78
18. Washer.....	RNA963	\$ 1.50
19. Rubber Mount.....	RNC737	\$ 7.95
20. Washer.....	RNF433	\$ 2.95
21. Washer.....	RNI121	\$ 0.75
22. Washer.....	RNF429	\$ 0.65

**F Defender 110  
Rear Fuel Tanks**

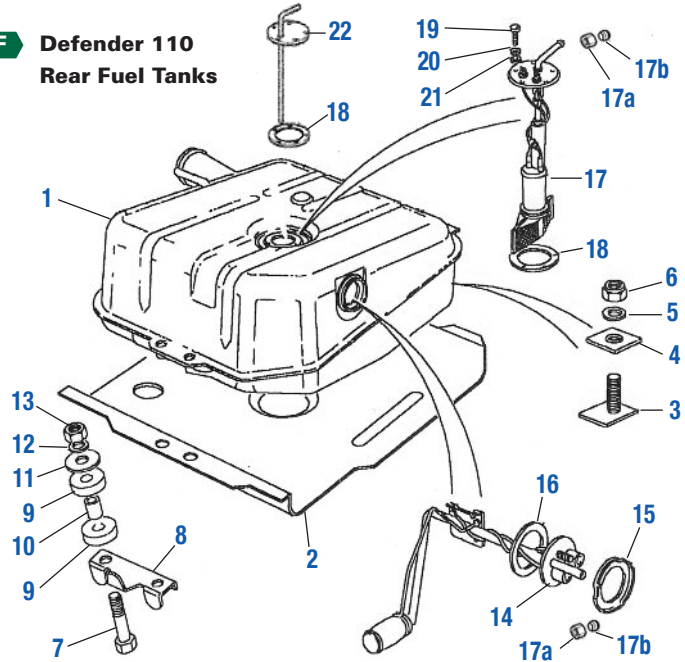

**F Defender 110 Rear Fuel Tank**

1. Fuel Tank, Rear Mount, Petrol, '93 110 NAS, Genuine.....	RNE114	\$ 1119.95
Fuel Tank, Rear Mount, Petrol, '93 110 NAS, Proline.....	PLE114	\$ 199.00
Fuel Tank, Rear Mount, Non-NAS, Diesel, Genuine.....	RNN180	\$ 954.76
Fuel Tank, Rear Mount, Non-NAS, Diesel, ProLine.....	PLN180	\$ 239.00
2. Cradle for Fuel Tank, Genuine.....	RNE116	\$ 112.95
Cradle for Fuel Tank, Proline.....	PLE116	\$ 79.50
3. Stud Plate Mount.....	RNN244	\$ 5.15
4. Spacer.....	RNN245	\$ 20.08
5. Plain Washer.....	RNF548	\$ 0.69
6. Nyloc Nut M8.....	RNE469	\$ 0.95
7. Bolt.....	RNN246	\$ 3.48
8. Tab Washer.....	RNN247	\$ 14.39
9. Rubber Washer.....	RNC148	\$ 2.19
10. Spacer Tube.....	RNN248	\$ 6.60
11. Plain Washer.....	RNF427	\$ 0.75
12. Lock Washer 10mm.....	RNF430	\$ 0.99
13. Nut M10.....	RNE158	\$ 0.66
14. Fuel Level Sender, Petrol.....	RNC854	\$ 129.84
Fuel Level Sender, Diesel, Genuine.....	RNH662	\$ 129.45
Fuel Level Sender, Diesel, ProLine.....	PLH662	\$ 51.45
15. Locking Ring.....	RNC886	\$ 4.99
16. Sealing Ring.....	RNC887	\$ 2.95
17. Fuel Pump, Genuine.....	RNF131	\$ POA
Fuel Pump, Proline.....	PLF131	\$ 98.20
17a. Union Nut (for attaching fuel line to pump) 2 required.....	RNF140	\$ 3.95
17b. Olive Fuel Feed (for attaching fuel lines to pump) 2 required.....	RNF136	\$ 1.95
18. Sealing Ring, Genuine.....	RNF425	\$ 4.95
Sealing Ring, Proline.....	PLF425	\$ 1.25
19. Fixing Screw.....	RNF264	\$ 1.49
20. Lock Washer 5mm.....	RND115	\$ 1.46
21. Plain Washer.....	RNF415	\$ 1.79
22. Fuel Pipe, Diesel.....	RNS722	\$ 59.95

**Defender Fuel Filters**

Fuel Filter, 200,300 Tdi, Genuine.....	RNF861	\$ 24.50
Fuel Filter, 200, 300 Tdi, ProLine.....	PLF862	\$ 7.90
Filter Change Kit, 300 Tdi, ProLine.....	RNK0001	\$ 42.50
Fuel Filter, Td5, Genuine.....	RND270	\$ 59.95
Fuel Filter, Puma Diesel 2.4 TDCi.....	RNI724	\$ 49.80
Fuel Filter, V8 petrol, threaded type, Genuine.....	RNF861	\$ 24.50
Fuel Filter, V8 petrol, threaded type, ProLine.....	PLF861	\$ 5.95
Fuel Filter, 2.5 NA, Genuine.....	RNC745	\$ 8.35



# BUILD YOUR ULTIMATE DEFENDER

[www.roversnorth.com](http://www.roversnorth.com)

Our new website makes it easy to find all the parts you need.

- Detailed Order Status
- Real Time Stock Availability
- Easy Shipping Calculator
- Track Shipments
- View web & phone orders
- View and print invoices
- Enhanced "Save Your Cart" Feature
- Many New Technical Diagrams
- Manage Your Rovers Magazine & Email Subscriptions Online

• **Introducing "Your Rover Garage"**  
Store information about your vehicles to ensure a perfect fitment on each order. Keep track of your model, VIN and modification notes.

• **Detailed Kit Component Viewer**  
Get a detailed look at what each kit contains, with links to explore the kit items individually. Includes real time stock availability.

Learn What's New at  
[roversnorth.com](http://roversnorth.com)



Check out the project  
Defender 90 on Facebook

Defender 90 custom  
build by Congleton  
Racing and Restoration.

