



A/C KIT INSTRUCTIONS COVERS:  
RNAC39 Defender 90 NAS V8, 3.9 litre  
RNAC40 Defender 90 NAS V8, 4.0 litre

## AIR CONDITIONING KIT INSTALLATION INSTRUCTIONS FOR LAND ROVER DEFENDER





A/C KIT INSTRUCTIONS COVERS:  
RNAC39 Defender 90 NAS V8, 3.9 litre  
RNAC40 Defender 90 NAS V8, 4.0 litre

## AIR CONDITIONING KIT INSTALLATION INSTRUCTIONS FOR LAND ROVER DEFENDER

### VEHICLE PREPARATION

1. Disconnect ground lead from battery then power lead from battery.
2. Remove the front grille. (See Figure 1)
3. Remove the front panel. (See Figure 2)
4. Remove "A" Frame support assembly. (See Figure 2)

### INTERIOR

1. Remove speakers from vehicle lower dash if fitted.
2. Remove fuse box cover.
3. Locate the brown seven way connector in the area behind the fuse box bracket.
4. Locate the oval firewall rubber plug on the right side of the fuse box and modify to allow the four prong white connector on the supplied A/C harness to pass through. (See Figure 3)
5. Drill a 2" diameter hole in the footwell to allow for evaporator tube. (See Figure 3)
6. Fit 2" grommet supplied into drilled footwell hole. (See Figure 3)
7. Vehicles fitted with lower dash speakers, drill out the two outer speaker fixing holes to 7mm diameter. Fit the two 90° dash brackets and weld nut brackets to the drilled out speaker holes as shown. (See Figure 4). Vehicles without lower dash speakers; fit the 90° dash brackets using 1/4" x 1" self-tapping screws supplied in the kit. This is best done by temporarily attaching the brackets to the Air Conditioning fascia assembly lifting into place and marking bottom of dash for location. On dash bottoms that are not solid (but have a concealed speaker hole behind vinyl dash covering) it is necessary to cut out the vinyl and install the weld nut bracket as supplied.  
NOTE: If you plan on fitting extra speakers in the provided speakers holes now is the best time to pre-wire speakers.
8. Lift the Air Conditioning fascia assembly into position on the vehicle dash paying particular attention to correctly aligning the Evaporator pipe with the 2" hole in RH footwell. (See Figure 4)
9. Centralize the fascia and using the center fixing screw hole as a location, drill a 5.5mm hole into the vehicle dashboard. Attach the Air Conditioning fascia using the longest self-tapping screw supplied in the kit.
10. Ensure that the Air Conditioning fascia is pressed firmly against the vehicle dash. Using the existing holes in each side of the Air Conditioning fascia, drill 3mm into the 90° brackets attached to the vehicles dash in step 7. Attach with the four black self-tapping screws supplied in kit.
11. Refit lower dash speakers, or blanking plates included in kit.
12. Connect the 3-way electrical harness (2 x brown 7-way connectors and 1 x white 4-way connector) to the fuse box connector block and the fascia connector block.

#### **FOR NAS VEHICLES not equipped with 7-way brown connector, wire as follows;**

- Connect an ignition feed onto white and green wire
- Connect a 30A main feed onto brown wire
- Connect an earth onto blue and black wire

13. Refit fuse box cover.
14. Fit rubber evaporator drain tube to evaporator. Drill suitable hole through the firewall using supplied grommet. This can be located in any convenient area by extending the rubber drain tube.

## AIR CONDITIONING KIT INSTALLATION INSTRUCTIONS FOR LAND ROVER DEFENDER

### ENGINE COMPARTMENT COMPRESSOR INSTALLATION

15. Assemble compressor to mount bracket using two (2) 3/8 x 5" bolts with flat and lock washers. (See Figure 14)
16. Loosen idler pulley for front fan belt.
17. Remove front fan belt from pulley so compressor drive belt can be installed to second groove of water pump pulley.

**NOTE: Remove and retain two (2) 6mm bolts which secure heater tube to the top of engine to allow clearance for compressor mount.**

18. Install compressor and bracket assembly to engine block using two (2) 3/8 x 1-3/4" bolts with flat and lock washers and one (1) 3/8 x 4" bolt with flat and lock washers.
19. Install idler assembly to bracket.
20. Route compressor V-belt around water pump pulley, clutch pulley and idler pulley.
21. Rotate idler pulley to increase belt tension as specified and torque bolt on idler to prevent slippage.
22. Reinstall front fan belt.
23. Rotate idler pulley to increase belt tension as specified and torque bolt on idler to prevent slippage.

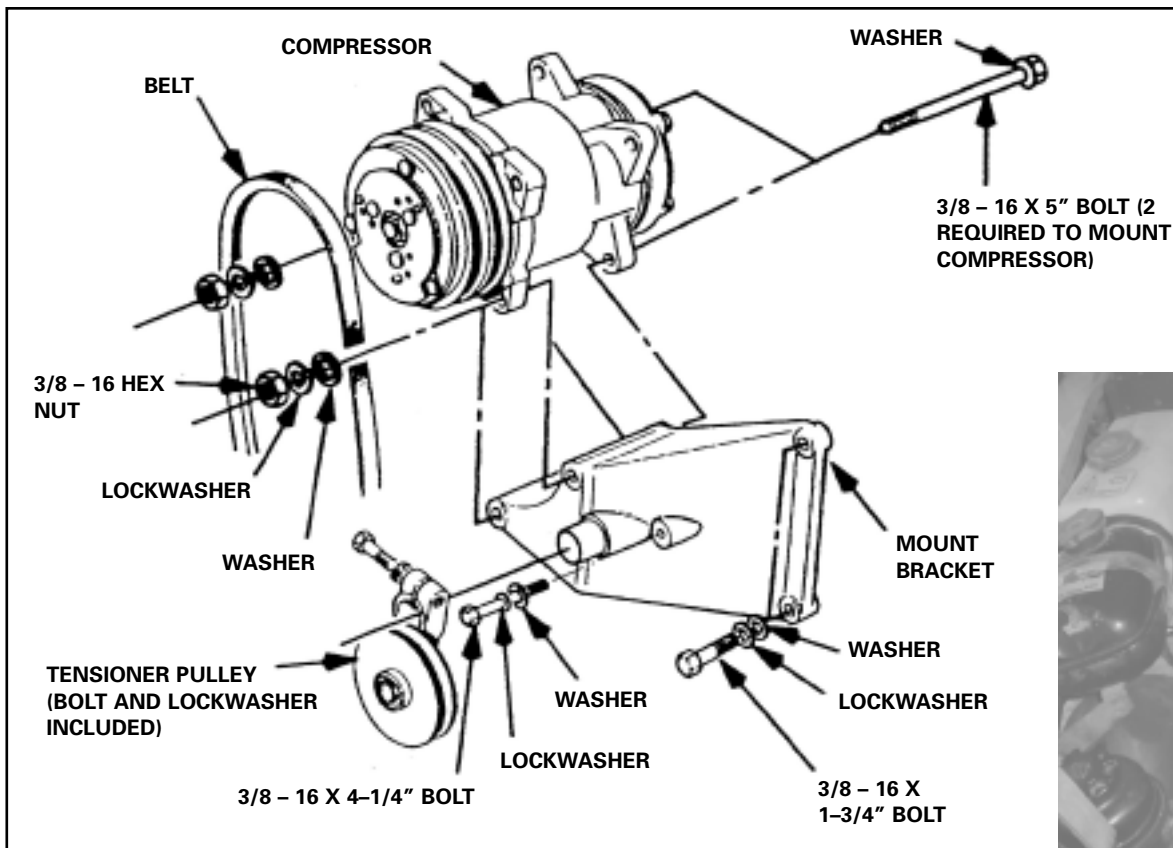

**FIGURE 6**



A/C KIT INSTRUCTIONS COVERS:  
RNAC39 Defender 90 NAS V8, 3.9 litre  
RNAC40 Defender 90 NAS V8, 4.0 litre

## AIR CONDITIONING KIT INSTALLATION INSTRUCTIONS FOR LAND ROVER DEFENDER

### ENGINE COMPARTMENT RECEIVER-DRIER INSTALLATION

24. Install the receiver-drier and bracket assembly to the RH frame rail using two (2) 5/16" x 3" bolts with flat washers and lock washers. (See Figure 5)

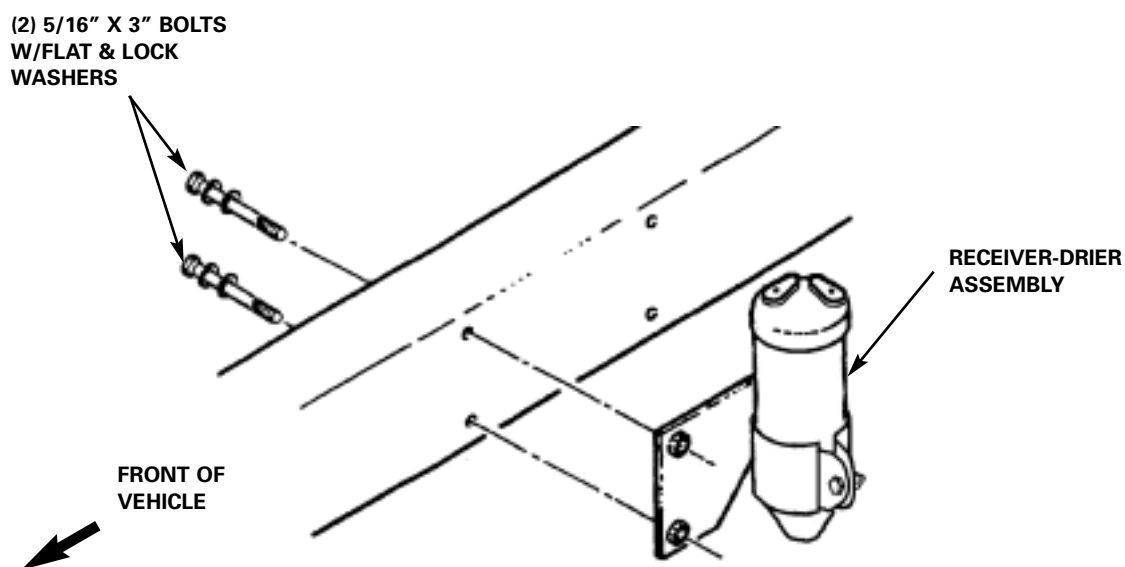

**NOTE: TWO SETS OF HOLES ARE ON FRAME RAIL,  
USE THE SET CLOSEST TO FRONT OF VEHICLE.**

**FIGURE 5**

### CONDENSOR FAN ASSEMBLY INSTALLATION

25. The Condensor Fan is pre-assembled in a frame that fits at the bottom to the "A" bar fixing points on the chassis rail and to grill panel fix points on both wings as shown in Figure 2. Re-fit the "A" bars over the condensor fan assembly of the radiator with the condensor fan facing forward with straight mounts on the bottom and angled mounts on top. (See Figure 2)
26. Fit pipes to receiver-drier and to evaporator unit. NOTE: Take care to fit pipes and hoses to connecting points leaving protective covers in place as long as possible. Fixing brackets should be installed in available locations.
27. Fit compressor hoses.

### FIT ELECTRICAL HARNESS AND CHARGE SYSTEM

28. Lay harness over the engine and plug into condensor fan and compressor. The compressor plug assembly locates onto the tabs on the compressor guard.
29. Ensure that the wiring harness is clear of any heat / damage sources and tie wrap in position.
30. Re-fit removed components from vehicle.
31. Fit A/C charge lable to the bonnet slam panel.
32. Charge the vehicle A/C system with 600 grams,  $\pm$  25 grams of R134a refrigerant gas.

## AIR CONDITIONING KIT INSTALLATION INSTRUCTIONS FOR LAND ROVER DEFENDER

### MOUNTING PONTS FOR CONDENSOR FAN ASSEMBLY

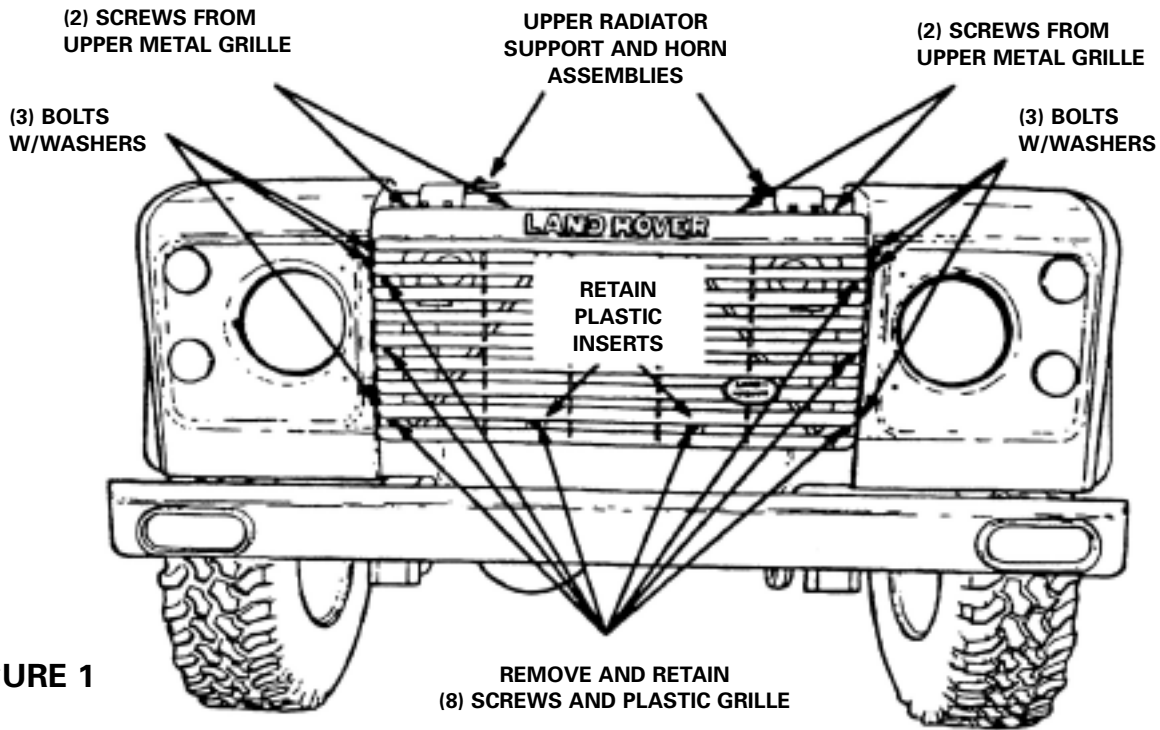

**FIGURE 1**

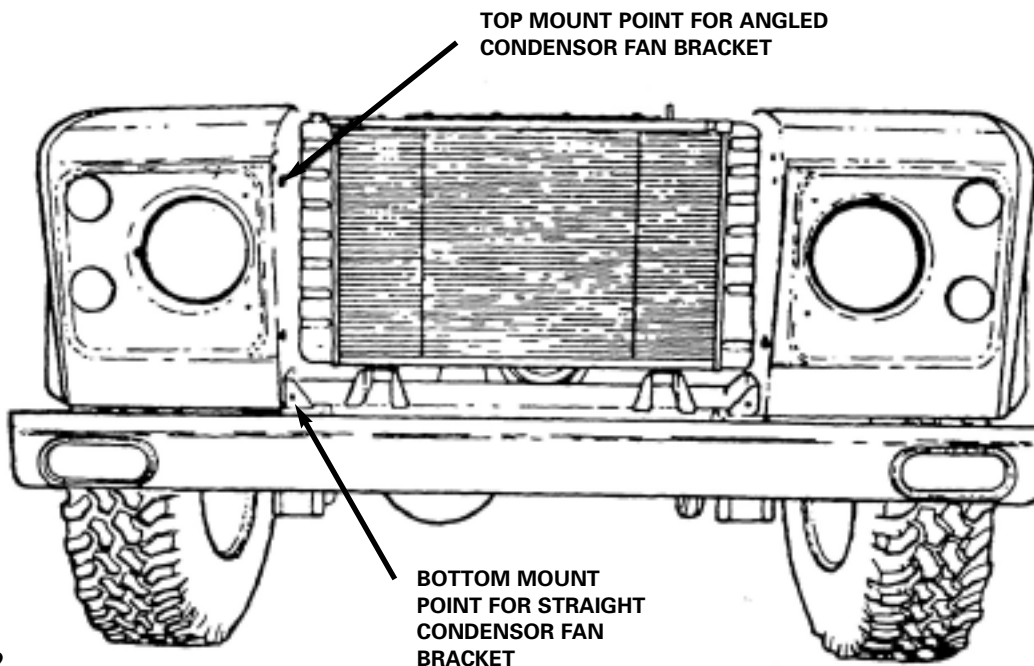

**FIGURE 2**



A/C KIT INSTRUCTIONS COVERS:  
RNAC39 Defender 90 NAS V8, 3.9 litre  
RNAC40 Defender 90 NAS V8, 4.0 litre

## AIR CONDITIONING KIT INSTALLATION INSTRUCTIONS FOR LAND ROVER DEFENDER

### BULKHEAD PREPERATION

Check the bulkhead area of the vehicle next to the fuse box. If there is a hole fitted with a grommet follow instuctions for early vehicles. If there is no hole follow instuctions for later vehicles.

**CAUTION: Care should be taken when drilling through into engine bay.**

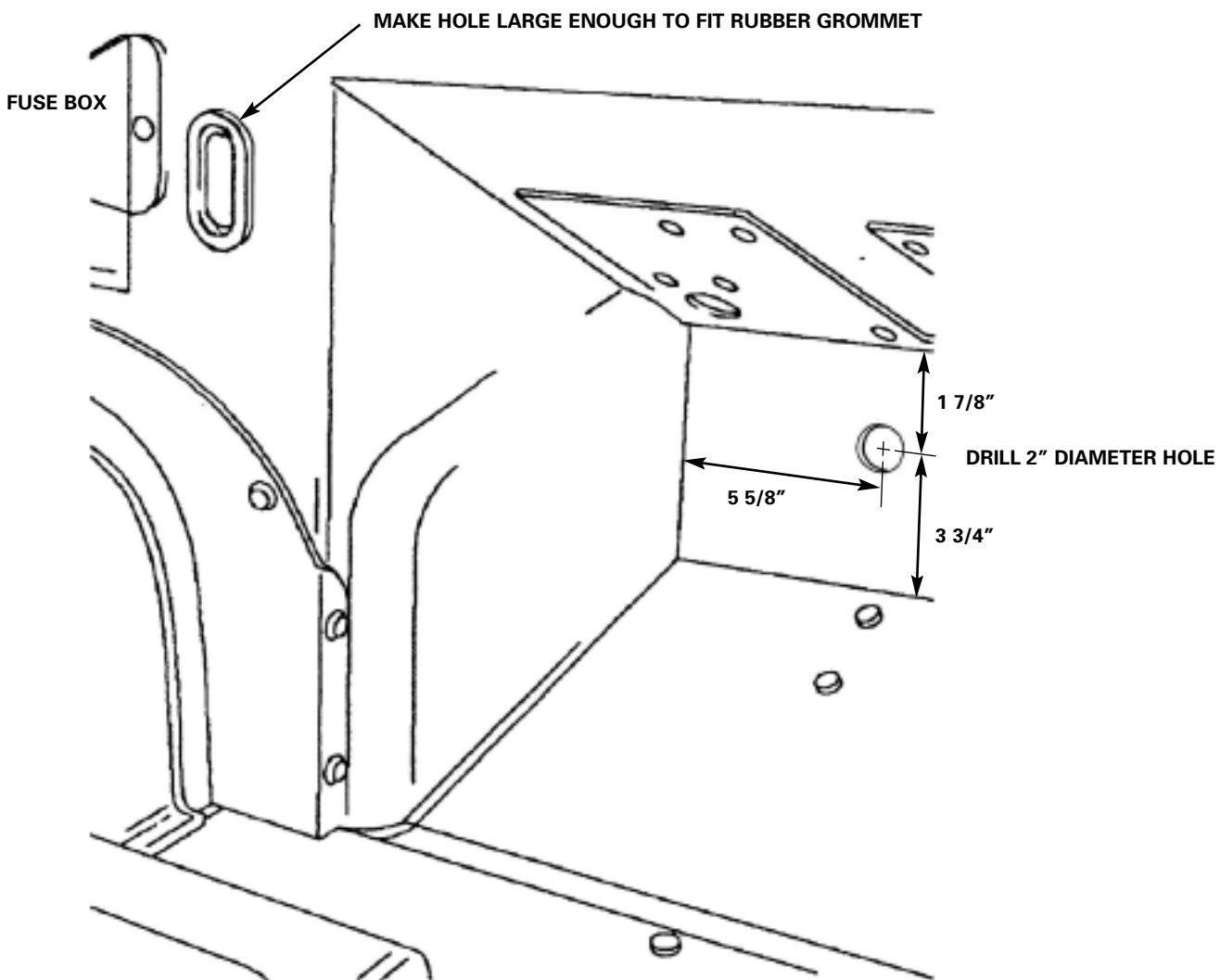

- Using template (supplied in kit), drill a  $\varnothing 20\text{mm}$  hole into the bulkhead on the passengers' side.

**FIGURE 3**



A/C KIT INSTRUCTIONS COVERS:  
RNAC39 Defender 90 NAS V8, 3.9 litre  
RNAC40 Defender 90 NAS V8, 4.0 litre

# AIR CONDITIONING KIT INSTALLATION INSTRUCTIONS FOR LAND ROVER DEFENDER

## FITTING AIR CONDITIONING FASCIA ASSEMBLY

**CAUTION:** Care should be taken when drilling through into engine bay.

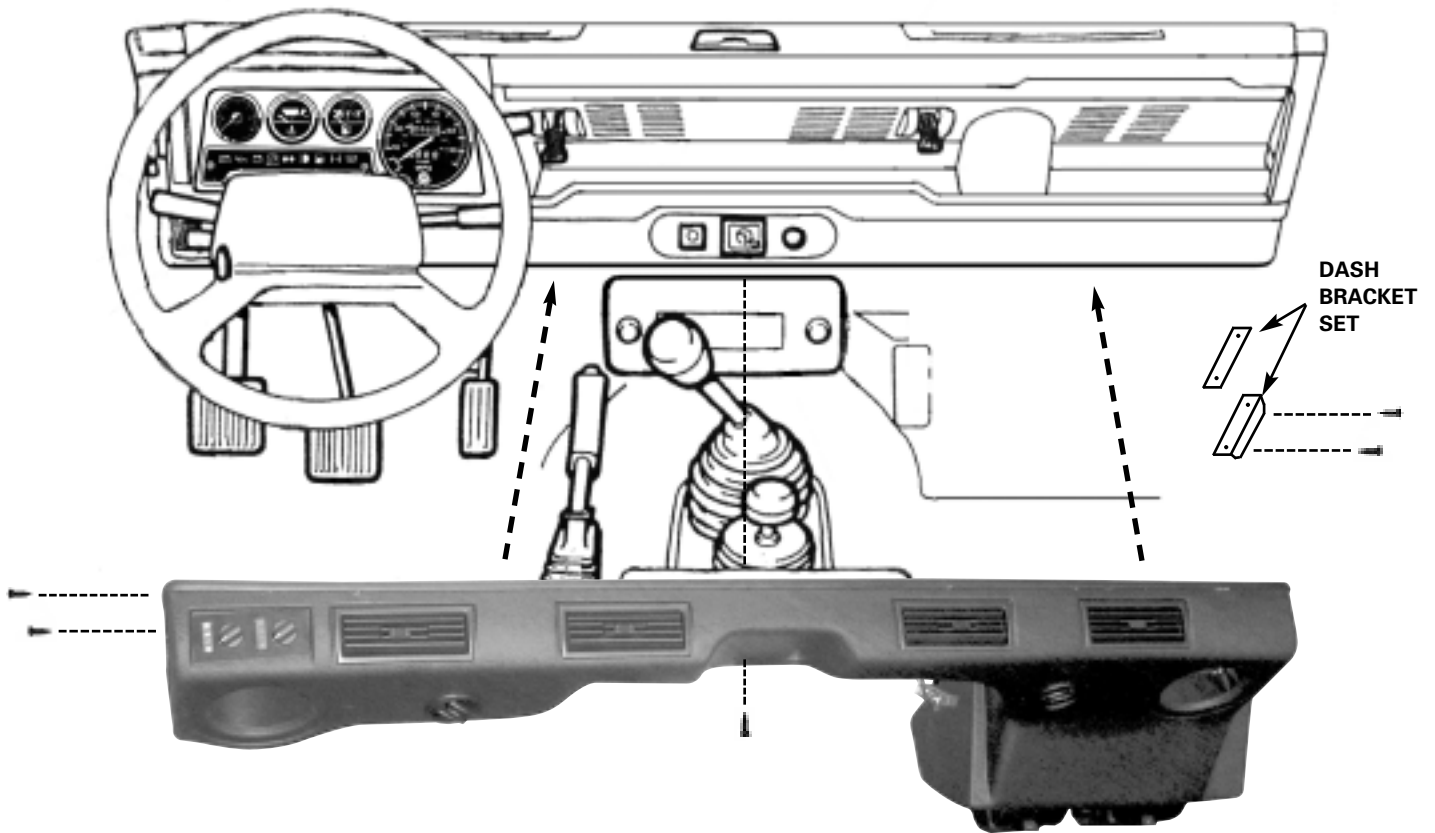
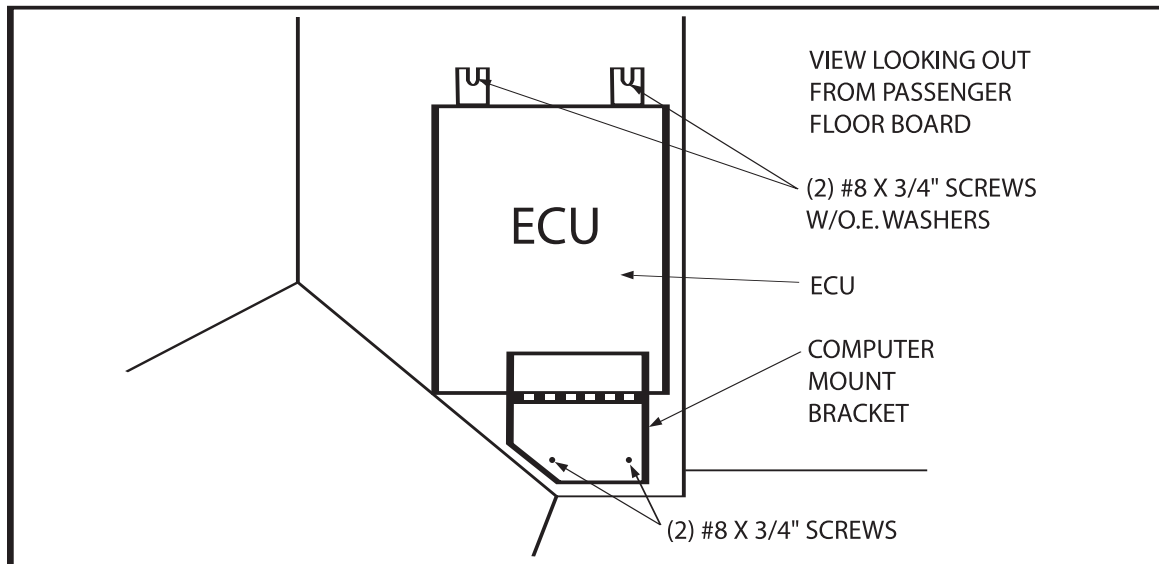

**FIGURE 4**

## SUPPLEMENT KIT A/C INSTRUCTIONS ECU RELOCATION FOR 1994 NAS DEFENDER 90 ONLY

### ECU RELOCATION FOR 1994 NAS DEFENDER 90 ONLY

1. Disconnect ground lead from battery then power lead from battery.
2. Remove and discard upper kick panel from passenger foot well compartment.
3. Disconnect main connector from ECU computer.
4. Remove ECU computer.
5. Re-install computer on the right outer kick panel fashioning suitable metal bracket as shown in the illustration. Mount bracket using two (2) #8 x 3/4" sheet metal screws. (See Figure 5 Below)



**FIGURE 5**

6. Mount computer with two (2) #8 x 3/4" sheet metal screws with original washers.
7. Re-attached main electrical connector to computer. **Loosen harness tape in engine compartment to help connector reach computer.**

**NOTE: - Caution - Once located on the outer kick panel, the ECU is venerable to water ingress. It is recommended that you rectify all water leaks in this area from dash and or door seals. You must protect the ECU from water contact.**



## SUPPLEMENT KIT A/C INSTRUCTIONS FOR 1997 NAS DEFENDER 90, 4.0 LITRE V8 ONLY

### COMPRESSOR MOUNTING FOR 1997 NAS DEFENDER 90, 4.0 LITRE V8 ONLY

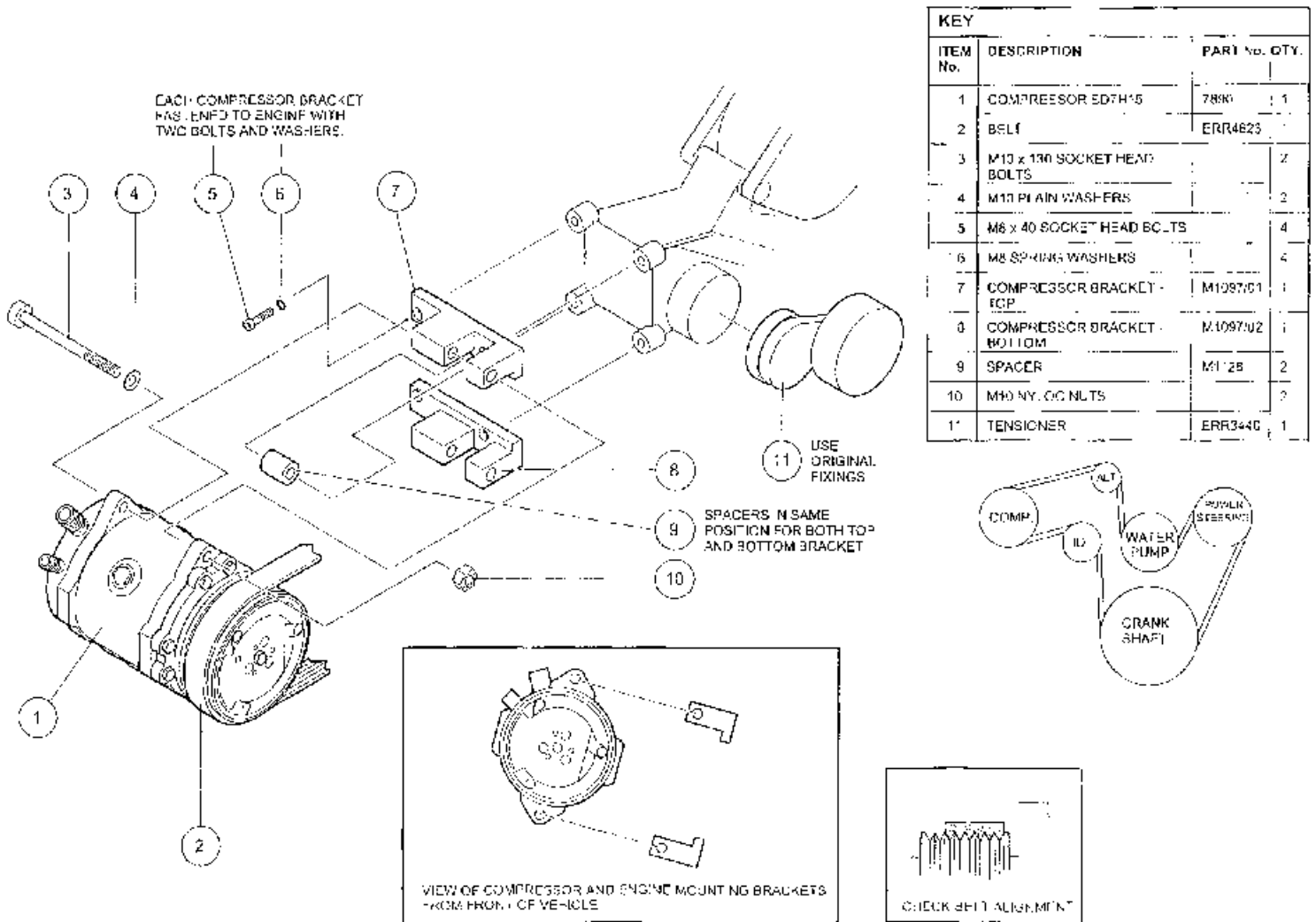
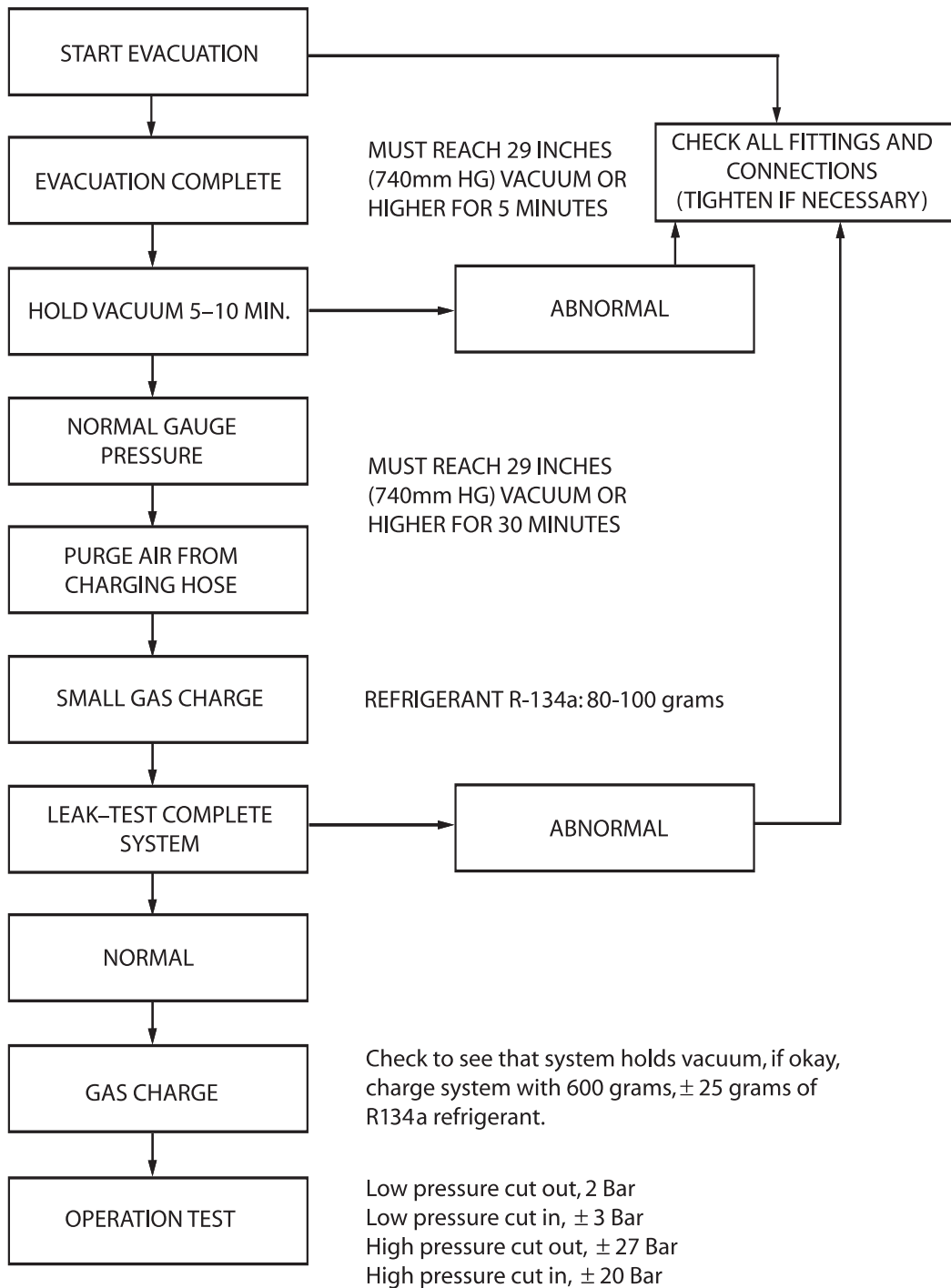

FIGURE 6

# EVACUATION AND CHARGING

**PREPARE VEHICLE FOR STARTING, FOLLOW PROCEDURE BELOW.  
 USE REFRIGERANT R-134a ONLY**





A/C KIT INSTRUCTIONS COVERS:  
RNAC39 Defender 90 NAS V8, 3.9 litre  
RNAC40 Defender 90 NAS V8, 4.0 litre

## PRECAUTIONS IN HANDLING REFRIGERANT PIPES

### **WARNING: Wear eye and hand protection when disconnecting components containing refrigerant. Plug all exposed connections.**

1. Charging or discharging the A/C system must only be carried out by qualified personnel that are familiar with the charging and recovery equipment. refer to the workshop manual for charging procedure.
2. When disconnecting any hose or pipe connection, the system must be discharged of all pressure. Proceed cautiously, regardless of gauge readings. Open connections slowly, keeping hands and face well clear, so that no injury occurs if there is liquid in the pipe. If pressure is noticed, allow it to bleed off slowly.
3. Pipes, flexible and connections and components must be capped immediately they are opened to prevent the entrance of moisture and dirt.
4. Any dirt or grease on fittings must be wiped off with a clean alcohol dampened cloth. DO NOT use chlorinated solvents such as Trichloroethylene. If dirt, grease or moisture cannot be removed from inside the hoses, they must be replaced with new hoses.
5. All replacement components and flexible end connections must sealed, and only opened immediately prior to making the connection.
6. Ensure the components are at room temperature before uncapping, to prevent condensation of moisture form the air that enters.
7. Components must not remain uncapped for longer than fifteen minutes. In the event of delay, the caps must be fitted.
8. Receiver/drier must never be left uncapped as it contains zeolite which will absorb moisture from the atmosphere. A receiver/drier left uncapped must not be used, fit a new unit.
9. The compressor shaft must not be rotated until the system is entirely assembled and contains a charge of refrigerant.
10. A new compressor contains the correct charge of refrigerant oil for the complete system. The compressor also contains a holding charge of gas when received, which should be retained until the pipes are re-connected.
11. The receiver/drier should be the last component connected to the system to ensure optimum dehydration and maximum moisture protection of the system.
12. All precautions must be taken to prevent damage to fittings and connections. Slight damage could cause a leak with the high pressures used in the system.
13. Always use two wrenches of the correct size, one on each fitting when releasing and tightening refrigeration unions.
14. Joints and 'O' rings should be coated with NDB refrigeration oil to aid correct seating. Fittings which are not lubricated with refrigerant oil are almost certain to leak.
15. All pipes must be free of kinks. The efficiency of the system is reduced by a single kink or restriction.
16. Flexible hoses should not be bent to be a radius less than 90mm radius.
17. Flexible hoses should not be within 100mm of the exhaust manifold.
18. Completed assemblies must be checked for refrigeration pipes touching metal panels. Any direct contact of lines and panels transmits noise and must be eliminated.



A/C KIT INSTRUCTIONS COVERS:  
RNAC39 Defender 90 NAS V8, 3.9 litre  
RNAC40 Defender 90 NAS V8, 4.0 litre

## GENERAL PRECAUTIONS

**WARNING: R134a is a hazardous liquid and when handled incorrectly can cause serious injury. Suitable protective clothing must be worn when carrying out servicing operations on the air conditioning system.**

**WARNING: R134a is odourless and colourless. Do not handle or discharge in an enclosed area, or in any area where the vapour or liquid can come in contact with naked flame or hot metal. R134a is not flammable but can form a highly toxic gas.**

**WARNING: Do not smoke or weld in area where R134a is in use. Inhalation of concentrations of the vapour can cause dizziness, disorientation, un-coordination, narcosis, nausea or vomiting.**

**WARNING: Do not allow fluids other than R134a or compressor lubricant to enter the air conditioning system. Spontaneous combustion may occur.**

**WARNING: R134a splashed on any part of the body will cause immediate freezing of that area. Also, refrigerant cylinders and replenishment trolleys when discharging will freeze skin to them if contact is made.**

**WARNING: The refrigerant used in an air conditioning system must be reclaimed in accordance with the recommendations given with a Refrigerant Recovery Recycling Recharge Station.**

**NOTE: Suitable protective clothing comprises: wrap around safety glasses or helmet, heat proof gloves, rubber apron or waterproof overalls and rubber boots.**

## REMEDIAL ACTIONS

1. If liquid R134a strikes the eye, do not rub it. Gently run large quantities of eyewash over the eye to raise the temperature. If eyewash is not available cool, clean water may be used. Cover eye with clean pad and seek immediate medical attention.
2. If liquid R134a is splashed on the skin run large quantities of water over the area as soon as possible to raise the temperature. Carry out the same actions if skin comes into contact with discharging cylinders. Wrap affected parts in blankets or similar material and seek immediate medical attention.
3. If suspected of being overcome by inhalation of R134a vapour seek fresh air. If unconscious remove to fresh air. Apply artificial respiration and/or oxygen and seek immediate medical attention.

**NOTE: Due to its low evaporating temperature of -30°C, R134a should be handled with care.**

**WARNING: Do not allow a refrigerant container to be heated by a direct flame or to be placed near any heating appliance. A refrigerant container must not be heated above 50°C.**

**WARNING: Do not leave a container of refrigerant without its cap fitted. Do not transport a container of refrigerant that is unrestrained, especially in the trunk of a car.**

## SERVICING EQUIPMENT

The following equipment is required for full servicing of the air conditioning system.

Recovery, recycling and charging station.  
Leak Detector.  
Thermometer +20°C to -60°C  
Safety goggles and gloves.



A/C KIT INSTRUCTIONS COVERS:  
 RNAC39 Defender 90 NAS V8, 3.9 litre  
 RNAC40 Defender 90 NAS V8, 4.0 litre

## AIR CONDITIONING KIT INSTALLATION INSTRUCTIONS FOR LAND ROVER DEFENDER

### TORQUE SPECIFICATIONS

DESCRIPTION	METRIC	ENGLISH
6MM HEATER TUBE BOLTS .....	15-20 N-M .....	(11-15 FT-LBS)
3/8 MOUNT BOLTS .....	40-50 N-M .....	(30-37 FT-LBS)
IDLER PULLEY BOLTS .....	14-16 N-M .....	(10-12 FT-LBS)
COMPRESSOR NUTS & BOLTS.....	40-50 N-M .....	(30-37 FT-LBS)
RECEIVER DRIER NUTS & BOLTS .....	35-40 N-M .....	(26-30 FT-LBS)
GENERAL 6MM NUTS OR BOLTS.....	20-25 N-M .....	(15-19 FT-LBS)
GENERAL 1/4-20 NUTS .....	20-25 N-M .....	(15-19 FT-LBS)

- **ALL HARDWARE USED TO FASTEN PLASTIC SHOULD BE TIGHTENED SNUG BUY NOT OVER-TIGHTENED WHICH WOULD CAUSE CRACKING.**
- **SCREWS THREADED INTO PLASTIC INSERTS SHOULD NOT STRIP PLASTIC THREADS.**
- **SHEET METAL SCREWS MUST BE TIGHT ENOUGH TO SECURE COMPONENTS WITHOUT ALLOWING VIBRATION.**
- **FRONT END SHOULD BE ASSEMBLED LOOSELY UNTIL ALL HARDWARE FITS TOGETHER BEFORE FINAL TORQUE DOWN.**

FRONT END BOLTS.....	40-50 N-M .....	(30-37 FT-LBS)
----------------------	-----------------	----------------

### HOSE AND TUBE FITTINGS

No. 6 FITTINGS – LIQUID HOSE AND TUBE .....	16-20 N-M .....	(12-15 FT-LBS)
No. 8 FITTINGS – DISCHARGE HOSE.....	19-24 N-M .....	(14-18 FT-LBS)
No. 10 FITTINGS – SUCTION HOSE .....	22-30 N-M.....	(16-22 FT-LBS)

**CAUTION: WHEN TIGHTENING FITTINGS, A BACK-UP WRENCH MUST BE USED TO INSTALL AT PROPER TORQUE WITHOUT DAMAGING FITTINGS.**

**BELT TENSION: IDLER PULLEYS SHOULD BE ALIGNED WITH CORRESPONDING PULLEYS SO BELT WEAR CAN BE HELD TO A MINIMUM AND BELT TENSION WILL BE MAINTAINED. CHECK BELT TENSION BY PUTTING THUMB PRESSURE ON BELT BETWEEN PULLEYS, MAXIMUM DEFLECTION OF BELT SHOULD BE APPROXIMATELY 6MM (OR 1/4”).**



T H E S P E C I A L I S T S I N L A N D R O V E R S • U S A

# Instructions Questionnaire

We rely on our customers to help us continually improve our instruction sheets. Please FAX or mail any comments, questions, or ideas for improvements you may have.

Send To: Rovers North  
1319 Vermont Route 128  
Westford, VT 05494

or Fax: 802-879-9152

Your Name: \_\_\_\_\_  
Address: \_\_\_\_\_  
\_\_\_\_\_

Phone #: \_\_\_\_\_  
Email Adrs: \_\_\_\_\_

Instruction part number (top right corner) or description of what instructions are: \_\_\_\_\_

Overall, how would you rate the quality of this set of instructions? (please circle one):

Poor		Fair		Good		Very Good		Excellent	
1	2	3	4	5	6	7	8	9	10
_____									

Ideas, Comments, or Corrections (please include specifics, such as page number, or step number):

\_\_\_\_\_

\_\_\_\_\_

\_\_\_\_\_

\_\_\_\_\_

\_\_\_\_\_

\_\_\_\_\_

\_\_\_\_\_

\_\_\_\_\_

\_\_\_\_\_

\_\_\_\_\_

**THANK YOU!**

**1 802 879-0032** or (800) 403-7591 • Fax: (802) 879-9152  
email@roversnorth.com • www.roversnorth.com

Rovers North, Inc. • 1319 VT Rt. 128 • Westford, Vermont • 05494-9601 USA